

# RICON DEALER NEWS

February 22, 2005

## PRODUCT & PERSONEL UPDATES

### FMVSS LIFT Update:

FMVSS 403 effective date is April 1, 2005. Ricon will continue to accept orders for non-complaint lifts until March 1<sup>st</sup> 2005. After March 1<sup>st</sup> all orders will be fulfilled with our fully compliant "public use" models. Available production capacity for non-compliant lifts is limited, so please place your orders NOW.

### The Standard in Occupant Safety:

At Ricon end user safety has always been a principle design requirement for all our products. Our new FMVSS 403 "public use" wheelchair lifts offer enhanced features that provide the ultimate in occupant safety, "The Ricon Safety Zone".

### Safety Zone Features

- Two Tiered Outer Barrier
- Reinforced Handrails
- Platform side barriers
- Automatic Inboard Rollstop
- New slip resistant finishes
- Improved platform lighting

Ricon's "Safety Zone" goes beyond minimum standards to insure **BOTH** wheelchair AND occupant are restrained with our patented electrically interlocked occupant restraint belt.

### More New Features:

- Dual Optical Threshold Warning System
- Lift "power" switch on illuminated Hand control
- Inboard Rollstop Interlock
- Cycle counter

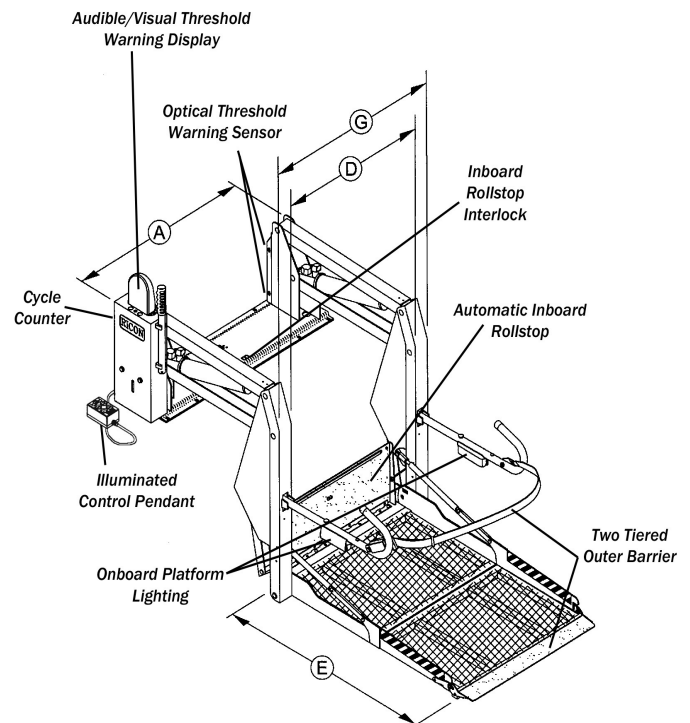

**RICON**<sup>®</sup>

INNOVATION IN MOBILITY™

# RICON DEALER NEWS

## Here We GROW Again:

**Ricon Elkhart** is open for business. The new facility will serve as a distribution and training center for the Midwest. **Rick Thompson** will assume the role of Warehouse General Manager and oversee day-to-day operations of the new facility.

We are very pleased to introduce the newest members to the Ricon team. **Mark Sarno** has recently been named Director of OEM sales. Mark will manage sales to School Bus and Paratransit vehicle manufacturers nation wide. **Joe Ordonez** and **Jake Craig** have been appointed Western and Midwestern Regional Sales Managers respectively. Both Joe and Jake come to Ricon with great enthusiasm and will provide sales support to Ricon dealers and end users. **Contact the Ricon team at 800-322-2884.**

### **West**

Joe Ordonez

Ext- 3038

[jordonez@riconcorp.com](mailto:jordonez@riconcorp.com)

### **Midwest**

Jake Craig

Ext- 3027

[jcraig@riconcorp.com](mailto:jcraig@riconcorp.com)

### **Northeast/Canada**

Francois Caron

819-475-1414

[fcaron@riconcorp.com](mailto:fcaron@riconcorp.com)

### **South**

Bill Hinze

Ext- 3012

[bhinze@riconcorp.com](mailto:bhinze@riconcorp.com)

### **Director - OEM Sales**

Mark Sarno

Ext-3046

[msarno@riconcorp.com](mailto:msarno@riconcorp.com)

### **V.P. - Commercial Sales**

Kevin Trudeau

Ext- 3004

[ktrudeau@riconcorp.com](mailto:ktrudeau@riconcorp.com)



INNOVATION IN MOBILITY™

# RICON DEALER NEWS

---

## Director – Customer Support

Larry McNutt

Ext-3075

[lmcnutt@riconcorp.com](mailto:lmcnutt@riconcorp.com)

## TRAINING, TRAINING, TRAINING

The Ricon Road Show is coming to a city near you. If you have not registered for one of your regional service schools, NOW is the time to do it. Upcoming schools will be in the following cities:

- March 7-8 – Sacramento, CA
- April 13 – Orlando, FL
- May 11 – Atlanta, GA
- June 8 – Dallas, TX

These training schools will be especially helpfully in understanding the new FMVSS 403 compliant lifts. Register online at [www.riconcorp.com](http://www.riconcorp.com).

All of us here at Ricon look forward to providing you with the best quality products and service in the industry. Our comments and suggestions are always welcome. Check our website at [www.riconcorp.com](http://www.riconcorp.com) for the latest news and announcements.



INNOVATION IN MOBILITY™