



Ricon®

A Wabtec company

MIRAGE®

F10X-SERIES™

DOT PUBLIC USE

MOTOR COACH ACCESS LIFT

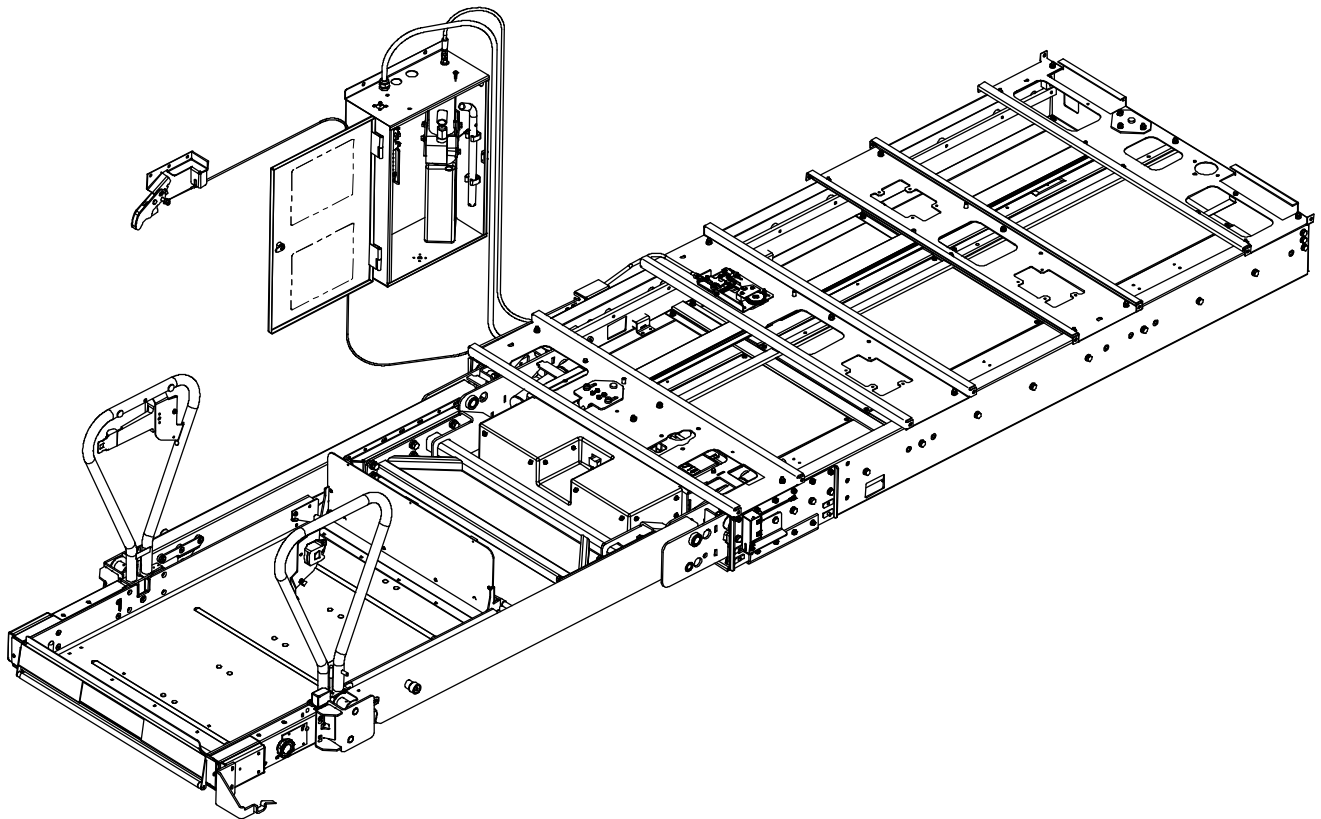

-PRINT-

SERVICE MANUAL

08/18/2021

32DF1002.C

©2021 RICON CORPORATION
All Rights Reserved

-HOME-

U.S. Patent Nos. 5,228,538; 5,373,915; 5,556,250;
6,043,741; 6,102,648, 6,236,905
Canadian Patent No. 2,129,821
Other U.S. and foreign patents pending.

Printed in the United States of America

This Ricon service manual is for use by qualified service technicians, and is not intended for use by non-professionals (do-it-yourselfers). The manual provides essential instructions and reference information, which supports qualified technicians in the correct installation and maintenance of Ricon products.

Qualified service technicians have the training and knowledge to perform maintenance work properly and safely. For the location of a qualified service technician in your area, call Ricon Product Support at 1-800-322-2884 or visit our website at www.riconcorp.com.

“DOT – Public Use Lift” verifies that this platform lift meets the public use lift requirements of FMVSS no. 403. This lift may be in-stalled on all vehicles appropriate for the size and weight of the lift, but must be installed on buses, school buses, and multi-purpose passenger vehicles other than motor homes with a gross vehicle weight rating (GVWR) that exceeds 10,000 lbs (4,536 kgs).

Customer Name: _____
Installing Dealer: _____
Date Installed: _____
Serial Number: _____

REVISION RECORD

REV	PAGES	DESCRIPTION OF CHANGE	ECO
32DF1002 C	2-1	Added Federal Motor Vehicle Safety Standard No. 404, Platform Lift Installations in Motor Vehicles (49 CFR 571.404) verbiage	9338

<u>Chapter</u>	<u>Page</u>
I. INTRODUCTION.....	1-1
A. WARRANTY INFORMATION.....	1-2
B. SHIPMENT INFORMATION.....	1-3
C. GENERAL SAFETY PRECAUTIONS.....	1-3
D. MAJOR LIFT COMPONENTS.....	1-4
II. INSTALLATION.....	2-1
A. MECHANICAL INSTALLATION.....	2-1
1. LIFT POSITIONING NOTES.....	2-1
2. LIFT MOUNTING NOTES.....	2-1
3. HYDRAULIC POWER UNIT.....	2-2
B. ELECTRICAL INSTALLATION.....	2-3
C. SAFETY INTERLOCKS.....	2-3
D. FINAL ADJUSTMENTS.....	2-4
1. HYDRAULIC BLEEDING.....	2-4
2. PLATFORM VERTICAL TRAVEL LIMIT ADJUSTMENT.....	2-5
3. BRIDGEPLATE ACTUATOR ROD ADJUSTMENT.....	2-5
4. PLATFORM HEIGHT ADJUSTMENTS.....	2-7
5. ANTI-STOW PRESSURE SWITCH ADJUSTMENT.....	2-9
6. ROLLSTOP ADJUSTMENT.....	2-9
7. VERIFY INSTALLATION.....	2-9
8. THRESHOLD WARNING SYSTEM ADJUSTMENT.....	2-10
E. CUSTOMER ORIENTATION.....	2-12
III. MAINTENANCE AND REPAIR.....	3-1
A. MAINTENANCE SCHEDULE.....	3-1
1. MAINTENANCE INTERVAL CHARTS.....	3-1
B. MAINTENANCE CHECKLIST.....	3-3
C. HYDRAULIC CIRCUIT DIAGRAM.....	3-5
D. ELECTRICAL WIRING DIAGRAM.....	3-6
1. DIAGRAM LEGENDS.....	3-6
2. WIRING DIAGRAM.....	3-8
IV. COMPONENT SERVICE.....	4-1
A. GENERAL SAFETY PRECAUTIONS.....	4-1
B. LIFT ACCESS FOR SERVICE.....	4-2
C. TRAVELLING FRAME.....	4-2
1. ROLLSTOP MAINTENANCE.....	4-3
2. BRIDGEPLATE MAINTENANCE.....	4-7
3. CARRIAGE AND LIFTING FRAME MAINTENANCE.....	4-8
4. PLATFORM REMOVAL.....	4-9
5. LIFTING FRAME REMOVAL.....	4-11
6. CARRIAGE REMOVAL.....	4-12
D. DEPLOYMENT SYSTEM.....	4-14
1. CARRIAGE DRIVE MOTOR ASSEMBLY.....	4-14
2. DRIVE CHAIN SERVICE.....	4-16
3. CARRIAGE LOCK ASSEMBLY.....	4-19
4. CARRIAGE RELEASE CABLE.....	4-20
5. CARRIAGE LOCK SWITCH.....	4-20
E. HYDRAULIC SYSTEM.....	4-21

- 1. SYSTEM FLUID RENEWAL..... 4-21
- 2. ELECTRIC PUMP MOTOR 4-21
- 3. HYDRAULIC CYLINDERS 4-22
- 4. ANTI-STOW PRESSURE SWITCH ADJUSTMENT 4-25
- 5. HYDRAULIC HOSE AND MAIN ELECTRICAL HARNESS 4-25
- 6. STOW LOCK ASSEMBLY..... 4-26
- F. ELECTRICAL CONTROLS..... 4-27
 - 1. GENERAL PROCEDURE FOR LIMIT SWITCH REPLACEMENT 4-27
 - 2. REPLACEMENT OF ELECTRONIC CONTROLLER..... 4-27
 - 3. HYDRAULIC HOSE AND MAIN ELECTRICAL HARNESS 4-28
- V. SPARE PARTS 5-1**
 - 1. DECAL LOCATIONS AND PART NUMBERS 5-4
 - 2. PUMP ASSEMBLY 5-6
 - 3. LIFTING FRAME ASSEMBLY..... 5-10
 - 4. ENCLOSURE ASSEMBLY 5-12
 - 5. PLATFORM ASSEMBLY 5-14
 - 6. CARRIAGE ASSEMBLY 5-18
 - 7. POWER ROLLSTOP ASSEMBLY, RIGHT SIDE..... 5-22
 - 8. ROLLSTOP LATCH, LEFT SIDE 5-24
 - 9. BRIDGEPLATE ASSEMBLY 5-26
 - 10. RELEASE HANDLE ASSEMBLY AND PENDANT ASSEMBLY 5-28
 - 11. STOW-LOCK ASSEMBLY 5-30
- F10X Lift Specifications 5-33

I. INTRODUCTION

The RICON Mirage® F10X-Series™ DOT Public Use Wheelchair and Standee lift provides safe and easy access to motor coaches for individuals using wheelchairs or scooters. The F10X-Series is installed in a motor coach baggage bay, or similar sheltered location. The lift is operated by the vehicle operator or a trained attendant.

An electric-motor driven hydraulic pump, driving dual hydraulic cylinders, provides smooth platform movement. Maximum lift capacity is 660 lbs. (300kgs). The operator uses the control pendant to withdraw the platform from the vehicle and lower it to the ground. A boarding passenger gets on the large non-skid platform, and is then raised to floor height. After the passenger enters the vehicle, the operator lowers the platform and retracts it back into the vehicle. When a passenger exits, the operator uses the control pendant to withdraw the platform from the vehicle and raise it to floor height. The passenger boards the platform, and is then lowered to the ground by the operator. The passenger departs, and the operator stows the platform.

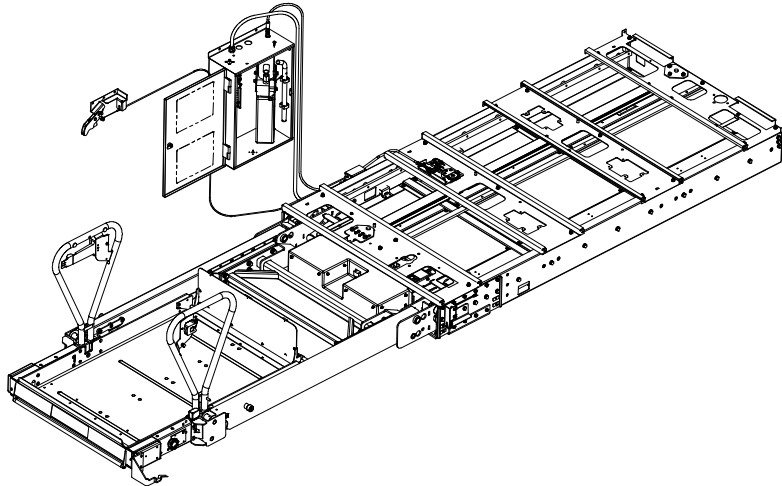

One individual can manually operate the lift when normal power is not present. A manual release mechanism is provided to ease the task of pulling the platform out of its enclosure. The hydraulic pump assembly includes a manually operated back-up pump to raise the platform, and a release valve to lower it. The front platform rollstop, normally power operated, has a manual override knob for back-up use.

This manual contains instructions for installation, maintenance, and service of major components, plus a chapter listing available spare parts. It is important for safety reasons that the service personnel be familiar with the Operating Instructions chapter in the Operator Manual.

This Service Manual provides information for installations that are either right-handed or left-handed. As a result, some manual illustrations may appear reversed when compared to your installation.

Please contact Ricon Product Support if you have questions about this manual, or need additional copies:

Ricon Corporation
1135 Aviation Place
San Fernando, CA 91340 (818) 267-3000
Outside (818) Area Code (800) 322-2884
World Wide Website www.riconcorp.com

Littlemoss Business Park, Littlemoss Road
Droylsden, Manchester
United Kingdom, M43 7EF (+44) 161 301 6000

A. RICON TWO-YEAR LIMITED WARRANTY

**RICON MIRAGE® F10X-SERIES™ DOT PUBLIC USE WHEELCHAIR LIFTS
TWO-YEAR LIMITED WARRANTY**

Ricon Corporation (Ricon) warrants to the original purchaser of this product that Ricon will repair or replace, at its option, any parts that fail because of defective material or workmanship as follows:

- Repair or replace parts for a period of two years from the date of purchase.
- Labor costs for specified parts replaced under this warranty for two years from the date put into service.

If you need to return a product: Return this product to Ricon, following the Ricon RMA procedure (available from Ricon Product Support). Please give as much advance notice as possible, and allow a reasonable amount of time for repair.

This warranty does not cover: Malfunction or damage to product parts caused by accident, misuse, lack of proper maintenance, neglect, improper adjustment, modification, alteration, the mechanical condition of the vehicle, road hazards, overloading, failure to follow operating instructions, or acts of nature (i.e., weather, lightning, flood)

Note: Ricon recommends that this product be inspected by a Ricon dealer or qualified service technician at least once every six months, or sooner if necessary. Required maintenance should be performed at that time.

 **WARNING**

THIS PRODUCT HAS BEEN DESIGNED AND MANUFACTURED TO EXACT SPECIFICATIONS.
MODIFICATION OF THIS PRODUCT IN ANY RESPECT CAN BE DANGEROUS.

This warranty is void if:

- The product has been installed or maintained by someone other than a Ricon dealer or qualified service technician.
- The product has been modified or altered in any respect from its original design without written authorization by Ricon.

Ricon disclaims liability for any personal injury or property damage that results from operation of a Ricon product that has been modified from the original Ricon design. No person or company is authorized to change the design of this Ricon product without written authorization by Ricon.

Ricon's obligation under this warranty is exclusively limited to the repair or exchange of parts that fail within the applicable warranty period.

Ricon assumes no responsibility for expenses or damages, including incidental or consequential damages. Some states do not allow the exclusion or limitation of incidental or consequential damages, so the above limitation or exclusion may not apply.

Important: The warranty registration card must be completed and returned to Ricon within 20 days after installation of this Ricon product for the warranty to be valid. The warranty is not transferable.

The warranty gives specific legal rights, and there may be other rights that vary from state to state.

B. SHIPMENT INFORMATION

Be sure the lift installation kit, if supplied, contains all the items listed on the kit packing list. Please report any missing items immediately to Ricon Product Support. The warranty and owner registration cards must be completed and returned to Ricon within 20 days to validate warranty.

Sales/Service Personnel must review the Warranty and this Operator Manual with the user to verify that safe operation of the product is understood. Instruct user to follow the operating instructions without exception.

C. GENERAL SAFETY PRECAUTIONS

The following general safety precautions must be followed during installation, operation, service, and maintenance:

- ˆ Do not attempt maintenance, repairs, or adjustments without the presence of a person capable of rendering aid.
- ˆ Attend all injuries, regardless of how slight. Administer first aid or seek medical attention immediately.
- ˆ Wear protective eye shields and appropriate clothing at all times.
- ˆ Exercise caution when operating lift to avoid injury. Be certain that hands, feet, legs and clothing are not in path of the platform as it moves.
- ˆ Be cautious when using metallic (conductive) tools near the battery.
- ˆ Check under vehicle before drilling or cutting to avoid damage to the frame, subframe members, wiring, hydraulic lines, etc.
- ˆ Thoroughly understand the operating instructions before attempting to operate lift.
- ˆ Inspect lift before each use. Do not operate lift if an unsafe condition is present, or if there are unusual noises or movements.
- ˆ Keep others clear of lift during operation.
- ˆ Maintain the lift at its highest level of performance by doing the required maintenance. Ricon recommends a thorough inspection every six months.

D. MAJOR LIFT COMPONENTS

Major components of the F10X-Series DOT Public Use Wheelchair and Standee Lift are called out in **Figure 1-1**. A description of each component is in **Table 1-1**.

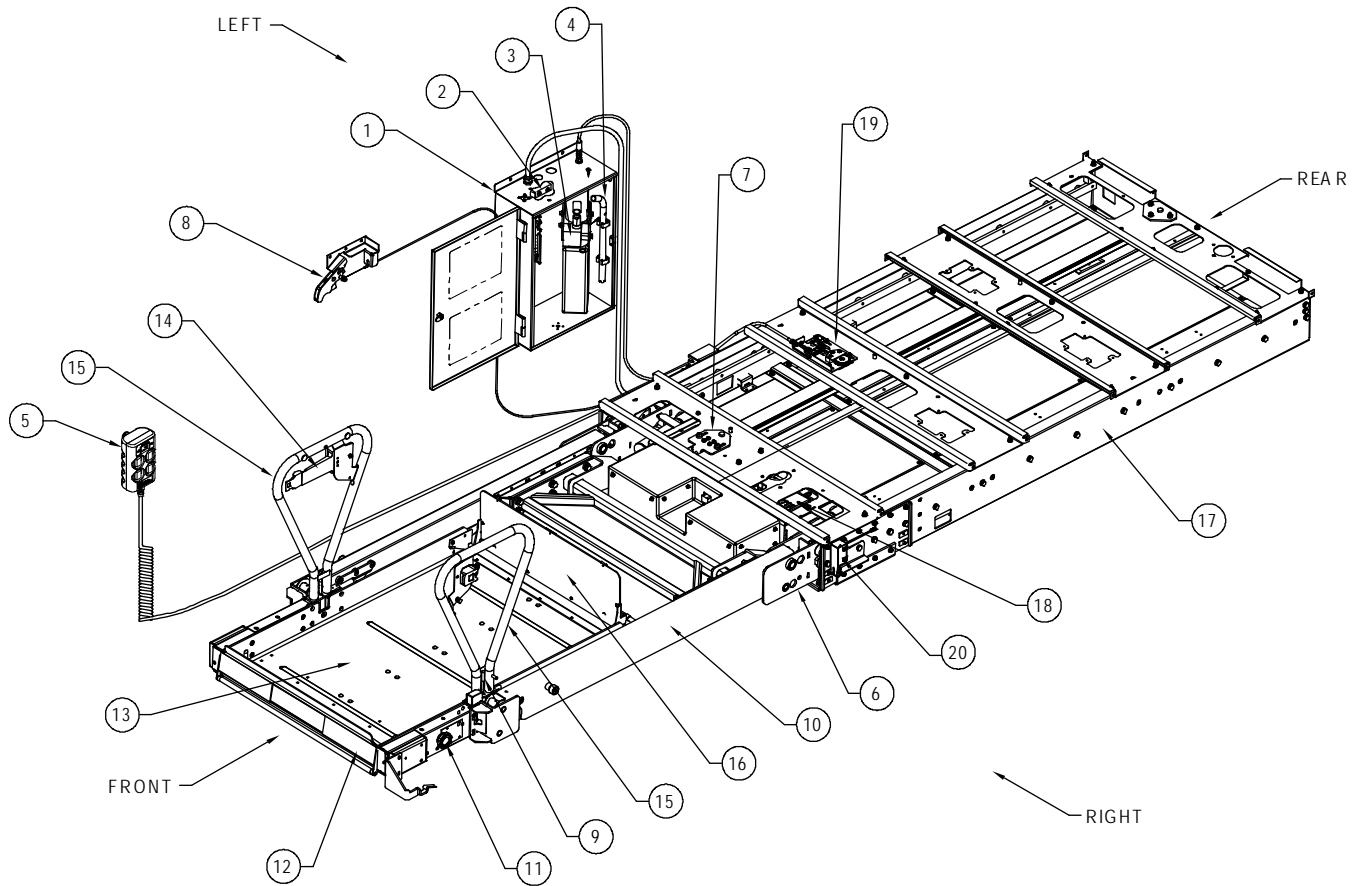

RSM0035500

TABLE 1-1: F10X-SERIES MAJOR LIFT COMPONENTS

REF	NAME	DESCRIPTION
Left, Right, Front, Rear		Reference points from outside of vehicle looking inward at lift.
1	Pump Enclosure	Contains lift electrical and hydraulic control components.
2	Electric Circuit Breakers	Prevents high-current damage to lift electrical components.
3	Hydraulic Pump Assy.	Electro-hydraulic unit provides hydraulic pressure used to raise platform.
4	Pump Handle	Used to manually operate hydraulic pump.
5	Control Pendant	Hand-held device used to control lift operation.
6	Carriage	Part of traveling frame that is mounted on rollers; moves on rails located inside enclosure. Supports lifting frame.
7	Deployment System	Part of carriage. Employs an electric gear-motor to propel platform out of enclosure, or pull it back in.
8	Carriage Release Lever	Used when electric power is not available to lift. Disengages platform from enclosure to facilitate manual deployment. Actuated by squeezing trigger.
9	Slam-Lock Handle	Locks handrail in upright position. L-handle unlocks handrail from upright position before lowering.
10	Lifting Frame	Hinged arms that lift or lower platform; driven by twin hydraulic cylinders attached to carriage.
11	Manual Rollstop Override Knob	Provides manual control of rollstop if electrical power is lost.
12	Platform Rollstop	Front barrier prevents wheelchair from inadvertently rolling off the platform during lift use.
13	Platform	Curbed area occupied by passenger during lift operations.
14	Occupant Restraint Belt	Occupant Restraint Belt helps prevent unintentional acceleration of wheelchair from platform. Electrically interlocked so that "UP" and "DOWN" functions are disabled if the belt is unbuckled.
15	Standee Handrails	Provides platform occupant with a stable handhold.
16	Bridgeplate	Plate unfolds when platform is at floor height to bridge gap between platform and vehicle interior.
17	Enclosure	Platform housing is rigidly attached to vehicle chassis.
18	Controller	Translates pendant command signals to control lift electrical and hydraulic components. Monitors lift functions.
19	Carriage Drive Chain Lock Assy.	Fastened to enclosure. Operated by carriage release lever. Normally holds carriage drive chain stationary. Can be disengaged to ease manual movement of platform.
20	Stow Lock Assembly	Secures travelling frame and carriage within the enclosure. Releasing the stow lock will allow the travelling frame to deploy.
END OF TABLE		

This page intentionally left blank.

II. INSTALLATION

The RICON F10X-Series DOT Public Use Wheelchair and Standee lift is contained in an enclosure. The enclosure is mounted in a motor coach baggage bay, or similar sheltered location. Specific information for every possible installation is not provided due to the wide range of applications. Contact Ricon Product Support if your particular application isn't covered here, or you have other installation questions.

NOTE: Public use vehicle manufacturers are responsible for complying with the lift lighting requirements in Federal Motor Vehicle Safety Standard No. 404, Platform Lift Installations in Motor Vehicles (49 CFR 571.404)

Illustrations used in this chapter apply to both right-handed and left-handed models. Therefore, some views may appear reversed when compared to the application being worked on.

- The following procedures are general, and apply to most baggage bay installations.
- Installation is carried out in four steps:
 1. Mechanical
 2. Electrical
 3. Final Adjustments
 4. Installation Verification

MECHANICAL

1. LIFT POSITIONING NOTES

Select baggage bay or a similar sheltered location within the vehicle to install lift. The lift mounting position is decided by the platform path of motion, relative to the ground and the vehicle interior floor. The platform must move through its range of travel without obstruction.

2. LIFT MOUNTING NOTES

- a. Refer to **Figure 2-1**. The weight of the lift is carried by the vehicle frame at eight mounting points (four on each side of enclosure). There are twelve M12x1.75 threaded inserts on the enclosure (six on each side). A minimum of four points must be used on each side of the enclosure, which will include both front points (select at least two of the rear mounting points).

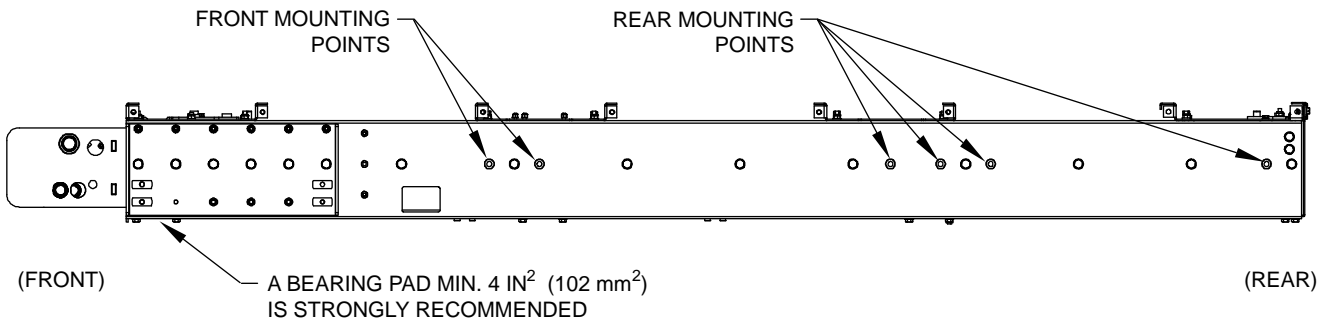

RSM0031301

FIGURE 2-1: LIFT ENCLOSURE MOUNTING POINTS (RH SIDEVIEW)

- b. Mounting brackets to attach the lift to the vehicle are not supplied, because the mounting method varies from one application to another. The method used must meet the load requirements in **Table 2-1**.

TABLE 2-1: LOAD CAPACITY REQUIREMENTS FOR LIFT MOUNTING BRACKETS		
Loading Direction	Front Supports (total capacity for left and right side support points)	Rear Supports (total capacity for left and right side support points)
Vertical	6,000 lbs (2,730 kg)	4,500 lbs (2,045 kg)
Longitudinal (perpendicular to drive axle)	4,000 lbs (1,820 kg)	4,000 lbs (1,820 kg)
Lateral (parallel to drive axle)	2,000 lbs (910 kg)	2,000 lbs (910 kg)
END OF TABLE		

 **CAUTION!**

Fasteners used for lift mounting must not protrude into the interior of the enclosure. An over-length fastener could contact something inside the enclosure, preventing its head from seating on the mounting bracket. The loose fastener would not secure the mounting bracket.

- c. Use M12x1.75 threaded screws, grade 8.8, or higher, for mounting the lift. Their length must provide at least 5/16 in. (8mm) of thread engagement with the inserts, but no more than 7/16 in. (11mm). Use washers under the screw heads. The screws must be plated and clean, but do not need to be lubed. Torque the fasteners to 66 foot-pounds (86 newton-meters).
- d. If the screw holes in the brackets are converted to slots, the slots must be horizontal. Horizontal slots, as opposed to vertical slots, will stop the lift from slipping downward if the hardware were to loosen.
- e. Vertical height adjustment is accomplished by placing shims between each mounting bracket upper surface and the vehicle frame. Maximum shim thickness is 1/8 in. (3mm).
- f. The top four corners of the enclosure must be in the same plane, +/- 1/8 in. (3mm). Shim, as required.
- g. Mounting brackets must be protected against rust and corrosion by painting, or similar treatment.

3. HYDRAULIC POWER UNIT

a. Hydraulic Power Unit Mounting Notes

- ⌘ The hydraulic power unit must be located so that operator has a clear view of platform while operating manual back-up system.
- ⌘ Load capacity of brackets used to mount the hydraulic power unit must meet the criteria in **Table 2-2**:

TABLE 2-2: LOAD CAPACITY REQUIREMENTS FOR HYDRAULIC POWER UNIT MOUNTING BRACKETS	
LOAD DIRECTION	BRACKET CAPACITY
Vertical	125 lb (57kg)
Longitudinal (perpendicular to drive axle)	200 lb (91kg)
Lateral (parallel to drive axle)	100 lb (45kg)
END OF TABLE	

- ⌘ Meeting these criteria assures that the pump mounting will withstand normal loads occurring during transit, and also during manual pump use.
- ⌘ Be certain pick-up tube is oriented properly when pump assembly is horizontally mounted. Also, be certain breather plug oriented properly (requires elbow fitting).

b. Power Unit to Pull Box Connection

- 1) Connect main hydraulic hose to hydraulic power unit, if not already done.
- 2) Operate manual backup pump until hydraulic fluid flows out open end of hose.
- 3) Connect open end of hose to hydraulic fitting located on side of pull-box.
- 4) Deploy platform and lower to ground.

 **CAUTION!**

Check and add hydraulic fluid when platform is at **ground** level. Adding fluid when platform is raised will cause the oil reservoir to overflow when platform is lowered.

- 5) Remove temporary shipping plug on top of hydraulic pump reservoir. Verify that hydraulic fluid in reservoir is at FULL level. Add Texaco 01554 Aircraft Hydraulic Oil, or equivalent U.S. mil spec H5606G fluid, if necessary. Replace temporary plug with the supplied breather plug.
- 6) Refer to Final Adjustments section in this chapter for hydraulic bleeding procedure.

B. ELECTRICAL

Use the following procedure to connect power to lift.

NOTE: A dedicated, insulated 4 AWG return wire (ground) is recommended. In either case, be certain all connections are clean and secure.



CAUTION!

Check vehicle before drilling, cutting, etc. Do not drill into factory wiring, hydraulic lines, fuel lines, fuel tank, etc.

1. Install a 50 amp circuit breaker within 12 in. (305mm) of battery.
2. Cut one 3/4 in. (19.5mm) hole through vehicle floor or wall to gain access to underside of vehicle. Locate hole adjacent to hydraulic pump unit. Deburr hole and install rubber grommet.
3. Crimp a 5/16 in. (8mm) ring terminal to end of four gauge, red power cable, then fasten to power cut-off solenoid (located near hydraulic pump unit). Insert other end of red wire through grommet.

NOTE: Torque +/- cable fasteners that attach to pump solenoid to 15 in/lbs.



CAUTION!

When routing the power cable, avoid hazards such as driveshafts, moving suspension parts, exhaust system, etc.

4. Route cable along vehicle frame, etc, to circuit breaker location. Make sure cable does not interfere with moving parts or contact hot objects. Secure with cable ties every 18 in. (450mm).

NOTE: When the cable is passed through a body wall, or bulkhead, the hole used must be deburred and a grommet installed.

5. Cut red wire to an appropriate length for reaching the circuit breaker. Save the discarded wire.
6. Crimp a 1/4 in. (6mm) ring terminal to end of red wire, then fasten to circuit breaker AUX terminal.
7. Cut a 12 in. (305mm) length of wire from the previously saved heavy red wire, and crimp a 1/4 in. (6mm) ring terminal to both ends.
8. Fasten one end of wire to circuit breaker BAT terminal.



WARNING!

- WEAR PROTECTIVE CLOTHING AND EYE PROTECTION AT ALL TIMES. BATTERIES CONTAIN ACID THAT CAN BURN. IF ACID COMES INTO CONTACT WITH SKIN, IMMEDIATELY FLUSH AFFECTED AREA WITH WATER AND WASH WITH SOAP.
- ALWAYS WORK IN A PROPERLY VENTILATED AREA. DO NOT SMOKE OR USE AN OPEN FLAME IN THE VICINITY OF BATTERY.
- DO NOT LAY ANYTHING METALLIC ON TOP OF BATTERY.

9. Fasten other end of wire to POSITIVE battery terminal.
10. Connect supplied harness to connector at hydraulic pump and to connector at lift. Also, connect harness to pendant (or to pendant extension). Refer to electrical diagrams in Chapter III.

NOTE: Use of dielectric grease is recommended in conditions of extreme humidity.

C. SAFETY INTERLOCKS



WARNING!

- THE LIFT CONTROLS MUST BE DISABLED ANYTIME THE VEHICLE IS **NOT** SAFELY PARKED. VERIFY THAT LIFT OPERATION CONFORMS TO FMVSS 403 AND 404.
- INSTALLATION OF SAFETY INTERLOCKS FOR COMPLIANCE WITH DOT FMVSS REQUIREMENTS IS THE RESPONSIBILITY OF THE INSTALLER.

Refer to wiring diagrams in Chapter III. A 24 VDC voltage source from vehicle is applied to terminal seven on the user interface connector (located on pump enclosure) **WHEN VEHICLE IS SAFELY PARKED**. This complies with DOT and FMVSS interlock requirements.

D. FINAL ADJUSTMENTS

This section contains procedures that may be needed after installing the lift. It is not necessary to perform all procedures after lift installation, but only those that are determined to be needed. Additional maintenance and repair adjustment procedures are in Chapter IV.



WARNING!

FAILURE TO PROPERLY ADJUST EQUIPMENT MAY RESULT IN UNSAFE OPERATING CONDITIONS FOR THE LIFT USER.

1. HYDRAULIC BLEEDING

The hydraulic system fluid will contain air after installation of the lift into vehicle. It may also contain air as a result of doing maintenance or repairs. "Bleed" the hydraulic system to remove trapped air.



WARNING!

THE FOLLOWING PROCEDURE SHOULD BE DONE BY TWO PEOPLE. BE AWARE THAT AN UNSUPPORTED PLATFORM WILL DROP WHEN A BLEED VALVE IS OPENED.

- a. Fully deploy platform.
- b. Raise platform to floor height, and support.
- c. Gain access to carriage by opening service door located in baggage bay floor.



WARNING!

- WEAR PROTECTIVE CLOTHING AND EYE PROTECTION AT ALL TIMES. BATTERIES CONTAIN ACID THAT CAN BURN. IF ACID COMES INTO CONTACT WITH SKIN, IMMEDIATELY FLUSH AFFECTED AREA WITH WATER AND WASH WITH SOAP.
- ALWAYS WORK IN A PROPERLY VENTILATED AREA. DO NOT SMOKE OR USE AN OPEN FLAME IN THE VICINITY OF BATTERY.
- DO NOT LAY ANYTHING METALLIC ON TOP OF BATTERY.

- d. Disconnect positive battery cable in vehicle battery compartment.
- e. Locate the bleed valves on the top side of both hydraulic cylinders. Access to these valves is through slots in the carriage rear frame channel.
- f. Remove platform support.



WARNING!

THE FOLLOWING STEP OPENS THE HYDRAULIC BLEEDER VALVE AND WILL ALLOW THE PLATFORM TO SLOWLY DROP.

NOTE: The next step will spill hydraulic fluid; have dry rags on hand.

- g. Slightly open the bleed valves on both cylinders using a hex key wrench. Let air and hydraulic fluid escape from cylinders. Close bleed valves when there is no evidence of air escaping from either valve.
- h. Manually lower platform to ground.



CAUTION!

Check and add hydraulic fluid when platform is at ground level. Adding fluid with platform raised will cause oil reservoir to overflow when platform is lowered.

- i. Remove breather plug on the top of hydraulic pump reservoir. Make sure that hydraulic fluid in reservoir is at FULL level. Add only Texaco 01554 Aircraft Hydraulic Oil, or equivalent U.S. mil spec H5606G fluid and reinstall plug.
- j. Raise platform to floor height and repeat steps f-i until fluid from both bleed valves is free of air.
- k. Verify that both bleed valves are fully closed.
- l. Close service door in baggage bay floor.
- m. Reconnect positive battery cable at vehicle battery compartment.
- n. Stow platform.

2. PLATFORM VERTICAL TRAVEL LIMIT ADJUSTMENT

The following procedure checks and adjusts the height of the fully raised platform relative to the vehicle floor. The platform should be 1 in.–1 ½ in. (25mm–38mm) above the floor when the control pendant is used to raise the platform to floor height. Height adjustments are accomplished by rotating the hydraulic cylinder shafts relative to the rod end.



CAUTION!

Do not attempt to rotate hydraulic cylinder shaft if excessive resistance is felt. Determine cause of resistance and correct before rotating shaft.

NOTE: This procedure should be used to adjust vertical travel limit errors of less than 1 in. (25mm). Errors greater than 1 in. (25mm) must be adjusted by supporting platform, removing keeper plates (2 ea), and rotating the rod end.

- a. Raise platform until hydraulic cylinders are fully extended. Platform must be raised with pendant.
- b. Measure distance between floor and rear edge of platform. The platform must be 1 in.–1 ½ in. (25mm–38mm) above the floor. Note the amount of error, and whether platform needs to be raised or lowered. Also, note whether the error varies between the left side of the platform and the right side. Continue this procedure if adjustment is necessary.
- c. Lower platform so that jam nuts on hydraulic cylinder shafts are accessible. Support platform, and loosen jam nuts.



CAUTION!

Platform height must be the same at left and right sides after adjustment. Unequal heights can cause binding at the pivot points between platform and lifting frame, and between lifting frame and carriage. Binding can result in unsafe operation.

- d. Rotate both hydraulic cylinder shafts to raise or lower platform the required amount; rotate CCW to lower platform, and CW to raise. Rotate shafts equally, and do not rotate more than 1/2 turn at a time without checking result.

NOTE: The cylinder shafts have wrench flats adjacent to the threaded portion. Turn shafts only by grasping the wrench flats.

- e. Return platform to floor height (hydraulic cylinders fully extended) and check result. Repeat steps b. through e. if further adjustment is necessary.
- f. Tighten jam nuts.

NOTE: Reprogram stow height if a readjustment was made. Refer to the Platform Stow Height Adjustment section in this chapter.

3. BRIDGEPLATE ACTUATOR ROD ADJUSTMENT

The bridgeplate is unfolded from the platform with two rods. The length of the rods controls the angle of the bridgeplate relative to the platform. The rods are correctly adjusted if the bridgeplate is fully unfolded when platform arrives at floor height.



WARNING!

INCORRECT DEPLOYMENT OF BRIDGEPLATE CAN CREATE A DANGEROUS CONDITION FOR LIFT USERS, AND MAY CAUSE DAMAGE TO THE BRIDGE PLATE OR PLATFORM. VERIFY THAT BRIDGEPLATE IS CORRECTLY ADJUSTED.

- a. Deploy platform using control pendant (DEPLOY).
- b. Raise platform to floor height and support.

⚠ WARNING!

- WEAR PROTECTIVE CLOTHING AND EYE PROTECTION AT ALL TIMES. BATTERIES CONTAIN ACID THAT CAN BURN. IF ACID COMES INTO CONTACT WITH SKIN, IMMEDIATELY FLUSH AFFECTED AREA WITH WATER AND WASH WITH SOAP.
- ALWAYS WORK IN A PROPERLY VENTILATED AREA. DO NOT SMOKE OR USE OPEN FLAME IN THE VICINITY OF BATTERY.
- DO NOT LAY ANYTHING METALLIC ON TOP OF BATTERY.

- c. Disconnect positive battery cable at vehicle battery compartment.
- d. Refer to **Figure 2-3**. Locate adjuster on right side actuator rod assembly (actuator rod is attached to the lifting frame, near platform). Loosen both adjuster jam-nuts.

NOTE: The adjuster is right and left hand threaded, like a turnbuckle.

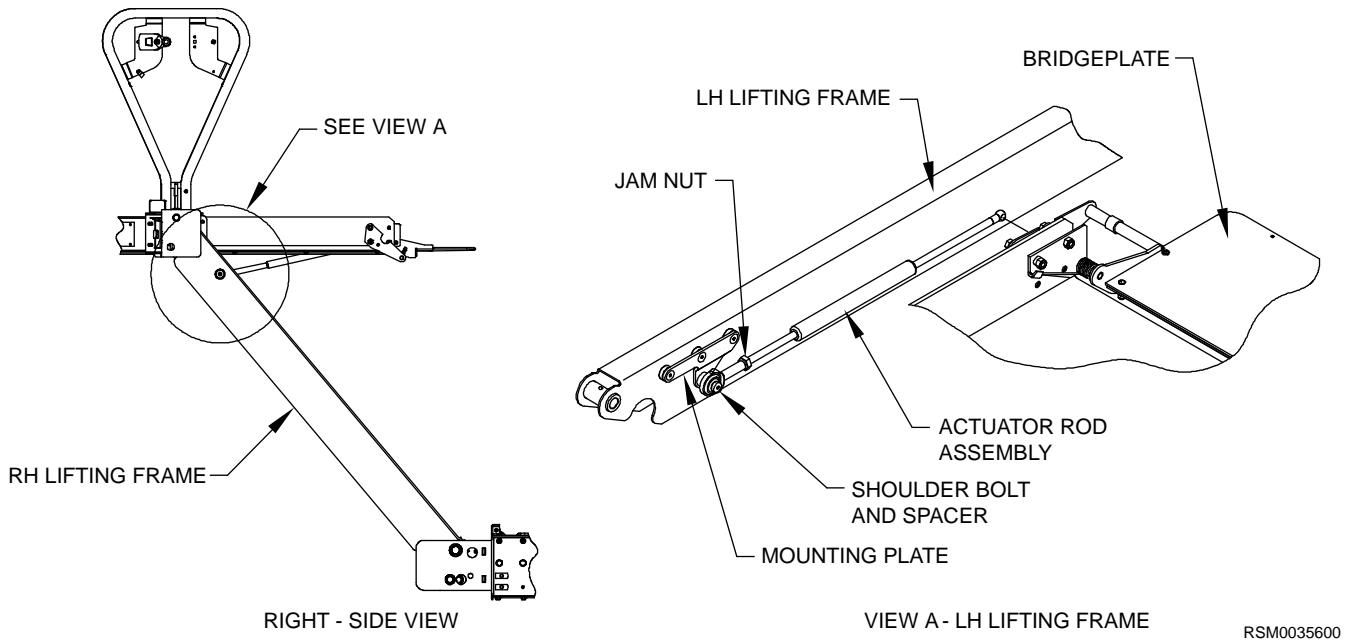

FIGURE 2-3: BRIDGEPLATE ACTUATOR ROD ASSEMBLY

- e. Remove shoulder bolt fastening left side actuator rod-end to mounting bracket (on lifting frame arm).
- f. Refer to **Figure 2-4**. Turn right side adjuster to achieve a clearance of 3/4 in. – 13/16in. (19mm-21mm) as noted in Figure 2-4 between bridgeplate cam and bridgeplate cam follower. Tighten adjuster jam-nuts.

NOTE: Lengthening actuator rods delays unfolding of bridgeplate, and shortening rods quickens unfolding.

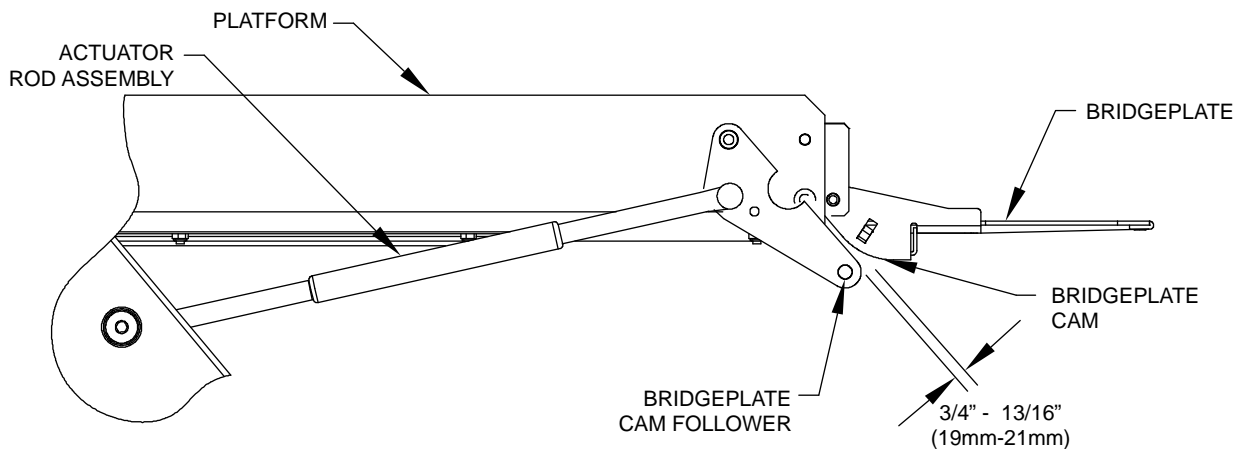

FIGURE 2-4: BRIDGEPLATE ADJUSTMENT

- g. Verify that bridgeplate is resting flat against vehicle floor. Adjust left side adjuster so that shoulder bolt can be installed without altering bridgeplate position. Install shoulder bolt, then tighten rod-end jam-nut.
- h. Reconnect positive battery cable at vehicle battery compartment.
- i. Remove platform support and operate lift to verify that bridgeplate deploys correctly. Readjust actuator rod assemblies, if necessary.

4. PLATFORM HEIGHT ADJUSTMENT

a. Program Stow Height:

The platform height just prior to being pulled into enclosure is referred to as “stow height”. When this height is properly set in the controller, the platform will enter enclosure without interference. The stow height is factory set and normally does not require resetting after lift installation, except when major lift disassembly has been done.

Stow height must be reprogrammed if the platform vertical travel limit has been adjusted.

A programming switch is available to program stow height into the controller memory. It is contained in Ricon Kit part number 17885.

NOTE: The stow height value is stored indefinitely in the controller memory. Programming the controller will clear the present value and store a new value.

- 1) Deploy platform using control pendant (DEPLOY).
- 2) Use manual back-up pump in combination with manual pressure release valve to bring the top surface of platform lifting arms parallel to top surface of carriage. This approximate stow height will allow the platform to be pushed into enclosure with minimum difficulty.
- 3) Refer to **Figure 2-5**. Release platform lock by pulling the manual release handle up (handle located in pump enclosure), and then hand-push platform partway into enclosure. Position platform so that the small lifting frame rollers are adjacent to the front end of the guide rail.

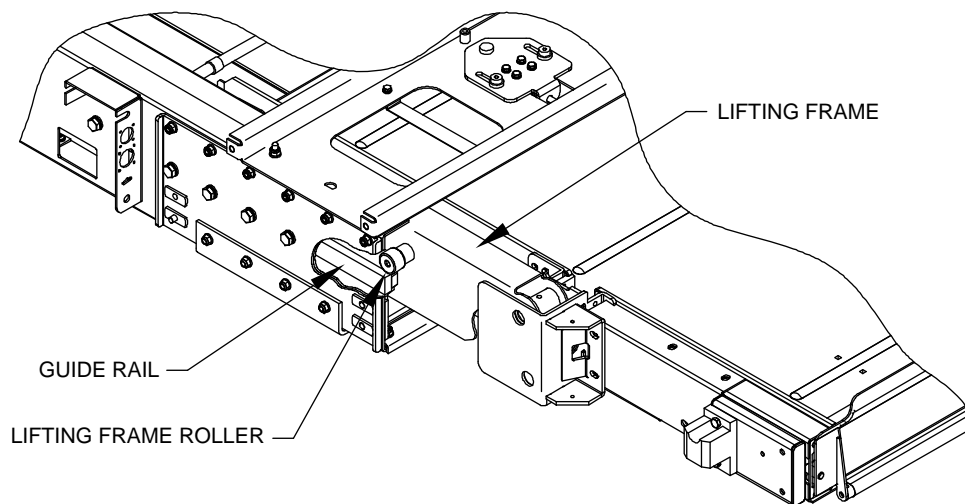

RSM0035800

FIGURE 2-5: LIFTING FRAME ROLLER TO GUIDE RAIL ALIGNMENT

- 4) Lower platform by opening manual pressure release valve (located on pump assembly), and let the small lifting frame rollers (left side and right side) settle on guide rails.
- 5) Raise platform with manual back-up pump so that rollers are approximately 1/32 in. (0.8mm) above guide rails.
- 6) Pull platform completely out of enclosure by hand, and then lower manual release handle (in pump enclosure) to lock carriage-platform in place. Check Stow Lock by attempting to push platform into enclosure until stow lock weldment engages stow lock and locks carriage. Lift must not move. This will assure accurate data entry.

NOTE: The platform must be fully deployed before controller can accept a stow height value.

- 7) Refer to **Figure 2-6**. The mating connector for the programming switch is located just below the cycle counter. The connector is protected with a removable dust cap. Connect programming switch and Program stow height by pressing Deploy button on the pendant three times, and then pressing the programming switch for approximately ten seconds. Disconnect programming switch and replace dust cap.

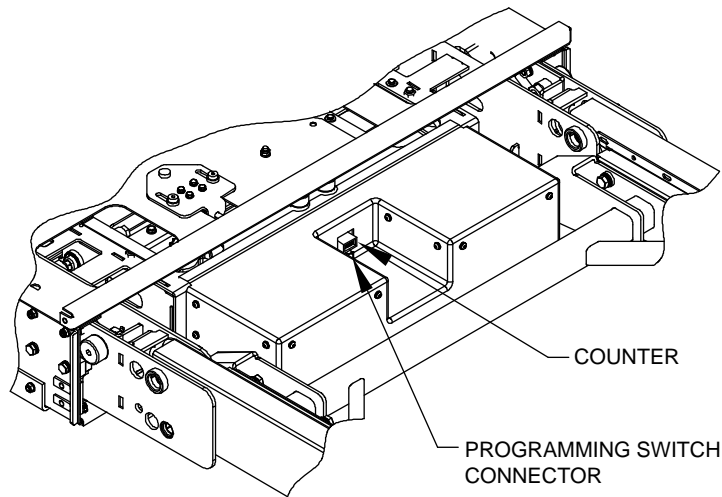

RSM0035900

FIGURE 2-6: PROGRAMMING SWITCH CONNECTOR

NOTE: The following test cycle might lower the platform to a point slightly below the programmed stow height. It is acceptable for controller to “overshoot” the programmed stow height during a test cycle; it will self-correct after being stowed from both directions.

- 8) Use pendant to raise platform at least 12 in. (305mm) above programmed stow height.
- 9) Stow platform from this raised position, but stop its movement when platform has entered enclosure approximately 6 in. (152mm).

NOTE: The following test cycle may possibly raise platform to a point slightly above the programmed stow height.

- 10) Deploy platform with pendant, and then lower it at least 12 in. (305mm) below programmed stow height.
- 11) Stow platform from this lowered position, and again stop its movement when platform has entered enclosure approximately 6 in. (152mm).
- 12) Repeat first test cycle (steps eight and nine).

b. Program Vehicle Floor Height

The baggage bay application is programmed to 1 ½ in. (38mm) above vehicle floor height. This height is typically 1 in. - 1 ½ in. (25mm-38mm) above vehicle floor level, and is also factory-set. The height can be reprogrammed for specific applications, or may need to be reprogrammed following major repair work.

An optional programming switch is available to program the stow and vehicle floor height into the controller memory. It is contained in Ricon Kit part number 17885.

⚠ CAUTION!

Ricon recommends that stow height be programmed before vehicle floor height.

NOTE: This procedure may require use of the manual back-up pump to raise platform because the pendant UP button may be disabled. The DOWN button can be used to lower platform.

- 1) Deploy platform using control pendant DEPLOY.

NOTE: The platform must be fully deployed before controller can accept the vehicle floor height value.

- 2) Raise platform to it's maximum upward travel to the vehicle floor level and verify that the lift platform is 1 in. – 1 ½ in. (25mm-38mm) above vehicle floor level.

NOTE: If platform is not set 1 in. – 1 ½ in. (25mm-38mm) above vehicle floor level, refer to Chapter 2, Section D.2 (Platform Vertical Travel Limit Adjustment) for adjustment.

- 3) Press the DEPLOY button three times then hold the UP button for ten seconds to program the vehicle floor height position into the controller.
- 4) Verify the programmed vehicle floor height position by stowing platform, then deploying and raising it to vehicle floor height using the control pendant.

NOTE: It is acceptable for the vehicle floor height position to vary +/- 1/2 in. (13mm) from the programmed height.

5. ANTI-STOW PRESSURE SWITCH ADJUSTMENT

An adjustable, pressure sensing, electrical switch is installed in the hydraulic line connected to the hydraulic cylinders. The pressure switch can detect the presence of a 50 lb. (23kg) load, or greater, on the platform. The anti-stow switch signals the controller when the platform is occupied. The controller inhibits horizontal platform movement if the platform is occupied, safeguarding lift users.

CHECK:

- Refer to **Figure 2-7**. Access to the pressure switch adjusting screw is at the lead wire end of the body. There is a locking set-screw on top of the adjusting screw. The locking set-screw must be removed to access pressure switch screw.

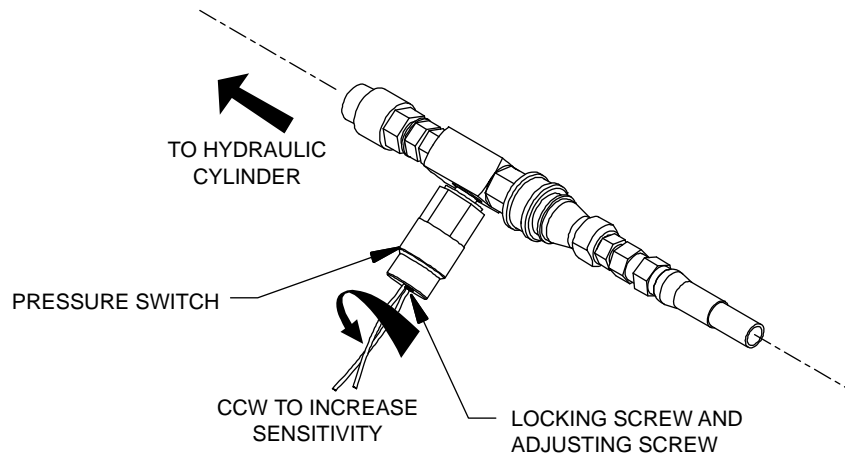

RSM0036000

FIGURE 2-7: ANTI-STOW PRESSURE SWITCH

- Apply power to lift and deploy platform.
- Lower platform to ground, and place a 50 lb. (23kg) weight in center of platform.
- Press STOW button until platform reaches STOW height. Platform should stop at stow height and not enter enclosure. Proceed to next step if platform attempts to enter enclosure.

ADJUST:

- Remove locking set-screw (requires hex key) and turn adjusting screw 1/8 turn CCW to increase sensitivity.
- Repeat above steps until the 50 lb. (23kg) weight inhibits stowing of platform. Repeat test from floor height; platform should stop at stow height and not enter enclosure.
- Remove test weight and then check platform stow function from ground height and from floor height. Platform should stow properly from either level. Replace locking set-screw.

NOTE: Normal platform operation may not occur if pressure switch adjustment is too sensitive (inhibits stow function when a weight that is significantly less than 50 lb. (23kg) is present). Turn adjusting screw CW to decrease sensitivity.

Also, erratic platform movement may occur if setting of pressure switch is marginal. Correct this by turning adjusting screw an additional 1/16 turn in appropriate direction.

6. ROLLSTOP ADJUSTMENT

Correct operation of the outer rollstop is essential to user safety. The rollstop is adjusted at the factory and should not require further adjustment after delivery and installation. Rollstop adjustment is not affected by the configuration of the installation. If there is any doubt about the rollstop operation, refer to "Rollstop Maintenance" in the "Traveling Frame" section of chapter four.

7. VERIFY INSTALLATION

- ◆ Installation of lifts must be performed by vehicle manufacturer's knowledgeable and qualified technicians for proper installation into vehicle manufacturer's baggage bay and follow all safety guidelines.
- ◆ Be certain there is no interference with operation of lift by interior or exterior components.
- ◆ The lift is designed to carry the weight of a wheelchair and its passenger, or a single standee. The vehicle structure must be adequate to support all loads produced during lift operation, as well as forces induced by vehicle motion during transit.

 <b style="font-size: 1.2em; margin-left: 10px;">CAUTION!
<ul style="list-style-type: none"> • <u>Do not operate lift during load test.</u> The load test is intended to test lift installation mounting points, not lifting capacity. Remove test weight immediately after test. • When test weight is placed on platform, the vehicle suspension will compress and vehicle will lean. If weighted platform touches ground, remove weight, raise platform, and then retest.

- ◆ The installed lift must be test loaded to 125% of its 660 lb. (300kg) rated load capacity to verify the installation integrity. Position platform 2 in.– 6 in. (51mm-152mm) above ground, and place 825 lbs. (374kg) in center of platform. Inspect lift mounting points. REMOVE TEST WEIGHT.
- ◆ Run lift through several complete cycles to verify proper operation.

8. THRESHOLD WARNING SYSTEM ADJUSTMENT

Though remotely installed and separately shipped, the Threshold Warning System (TWS) is required to achieve a lift system installation that is compliant with the requirements of FMVSS 403 and 404. The purpose of the TWS is to provide a visual and audible warning to a person in a wheelchair when they are in the threshold zone and the platform is more than 1 in. (25mm) below the vehicle floor level. The threshold zone is defined as the area across the front of the wheelchair lift access doorway, up to 18 in. (457mm) back into the vehicle.

There are four sections presented here. The first section adjusts where the acoustic beam is pointed, the second tests the accuracy of the adjustment, the third provides a procedure for adjusting the timing of the sensors, and the fourth section tests for Threshold Warning System (TWS) functionality.

Adjustment of the sensor timing is done at the factory and should not need to be repeated in the field. Readjustment should only be considered if the sensor aiming could not be adjusted to ignore both the wheelchair in the aisle and the platform during its normal movement.

The TWS must be oriented so that the acoustic sensors are closest to the vehicle doorway with the LED light oriented closest to the interior of the vehicle for maximum visibility. The TWS must be installed within 3 in. (76mm) of vehicle door center and no more than 72 in. (1828mm) above vehicle floor level so that a person in a normal seated position will activate the alarm when their heels are less than 18 in. (457mm) from the vehicle door threshold. Refer to **FIGURE 2-8**. Refer to Chapter 3, Section D.1.e for Wiring Diagram.

a. Adjust Aiming Of Acoustic Sensor Beam:

- 1.) Refer to **FIGURE 2-8**. Place wheelchair with passenger in center aisle of bus, pointed at doorway where Threshold Warning System (TWS) is installed. The TWS should not detect a wheelchair and passenger when they are located this far from doorway.

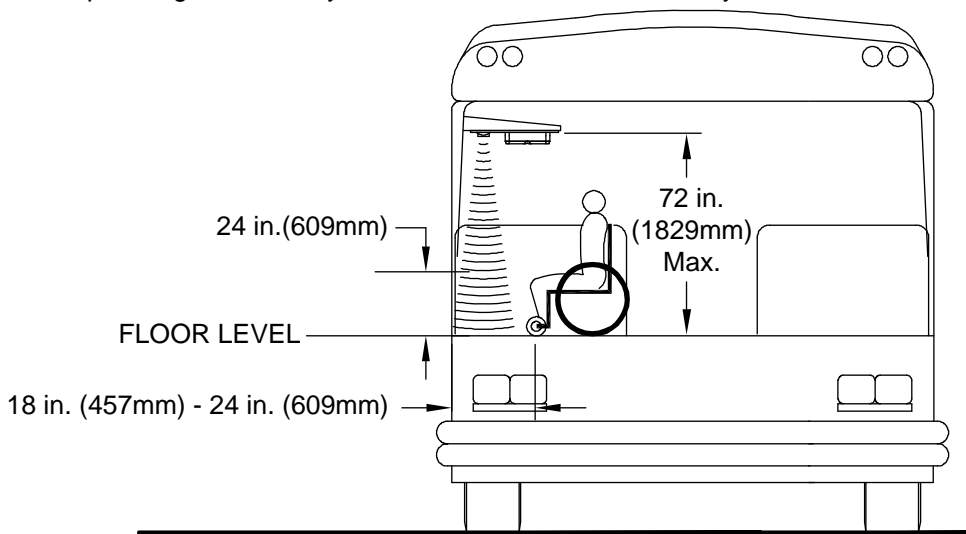

RSM0037101

FIGURE 2-8: TWS AREA

- 2.) Turn power to lift on (LED on TWS module will light steady) and enable power to lift. If wheelchair and passenger are detected by acoustic sensors the LED will flash, the buzzer will sound, and the large red light will flash. If this occurs it is necessary to adjust aiming of sensors.

- 3.) Refer to **FIGURE 2-9**. Turn sensor angle adjustment screw clockwise to move direction of beam away from center aisle and towards doorway.
- 4.) Stop adjustment when LED ceases to flash.

NOTE: Refer to **Figure 2-9**. Some applications may require shims to adjust the Acoustic Sensor Beam aim.

- 5.) Refer to **Figure 2-9**. Add 1/4" washer and 1/8" washer accordingly to shim one side of the TWS and adjust the Acoustic Sensor Beam aim away from obstructions such as chairs.

- 6.) Torque each TWS fastener to 40 in/lbs.

NOTE: Only in rare instances will adjustment be needed in the counterclockwise direction.

- 7.) Move centerline of small front wheels of wheelchair (with passenger) to within 24 inches of doorway and repeat aiming procedure in previous step.

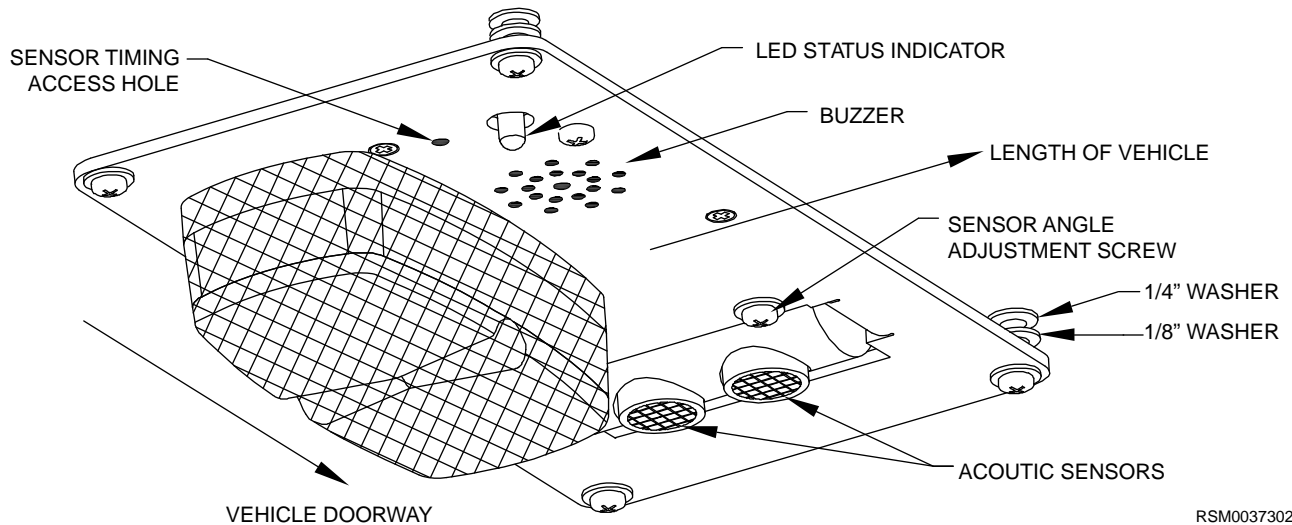

FIGURE 2-9: TWS MODULE DETAIL

b. Test Aim Of Acoustic Sensor Beam:

- 1.) Refer to **Figure 2-10**. Move wheelchair and passenger slowly towards doorway. TWS should detect wheelchair and passenger (LED will flash, the buzzer will sound, and the large red light will flash) when centerline of front wheels is between 18 in. and 24 inches from doorway.

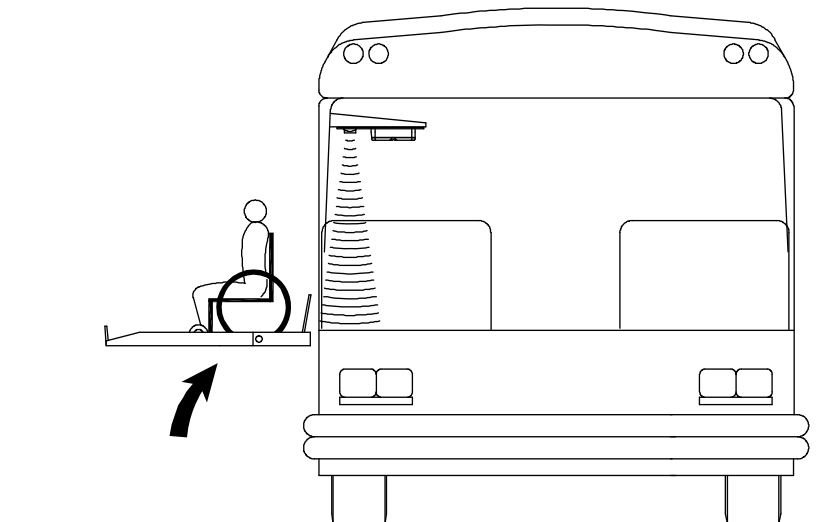

FIGURE 2-10: CHECKING NORMAL PLATFORM POSITION

- 2.) Open vehicle door above lift. Lower platform to ground and place wheelchair and passenger at rear of platform. Bridgeplate (rear barrier) should be up. Raise platform to floor level. This normal platform motion with wheelchair and passenger aboard should not actuate TWS. If LED does flash (buzzer will also sound and large red light will flash), turn sensor adjustment screw slightly counter-clockwise.

NOTE: If an adjustment is made, repeat the previous step where wheelchair is between 18 and 24 inches from doorway.

c. Adjust Acoustic Sensor Timing:

Refer to **Figure 2-8**. Support a flat sheet of cardboard, or similar material, directly beneath TWS module and at a distance of 24 in. (609mm) above floor level. Sheet must be facing sensors.

NOTE: Before proceeding, visually inspect sensors to verify that they are pointed directly at floor, or nearly, and are not pointed off at an extreme angle.

- 1.) Refer to **Figure 2-9**. Note the sensor timing access hole. This hole provides access to a plunger actuated switch that sets the sensor timing. Insert a 1/16 in. (1.6mm) diameter wire-like object into the access hole and press the plunger inward. The LED will flash momentarily while the module establishes the distance and then remain on steady. Release the plunger when the LED ceases to flash.

NOTE: It is important that objects, such as your body, tools, seats, etc, do not interfere with the beam while the adjustment is being made.

d. Test TWS Functionality

Activation of the TWS (i.e. the provision of visual and audible alarms with a wheelchair and passenger in the threshold area as prescribed in Section D.8.b., Test Aim of Acoustic Sensor) is controlled by the position of the linear potentiometer mounted inside the hydraulic cylinder and should occur within 1 1/2 in. (38mm) of the programmed vehicle floor height. With the platform upward travel limit setting executed as prescribed in Section D.2, Platform Vertical Travel Limit Adjustment, activation of the TWS should occur before the platform has descended more than 1 in. (25mm) below the vehicle threshold.

In the event the platform moves more than 1 in. (25mm) below the vehicle door threshold the TWS is activated. Refer to Section D.4.b, Program Vehicle Floor Height and make sure the unit has been properly programmed with the correct vehicle floor height setting.

- 1.) Raise an unloaded platform to vehicle floor level then place a wheelchair and passenger in threshold area. Verify that the TWS is enabled (Red LED Status Indicator flashing).
- 2.) Press DOWN button on pendant then release when TWS alarms activate. Verify that the platform distance below vehicle floor level is less than or equal to 1 in. (25mm).

E. CUSTOMER ORIENTATION

IMPORTANT
- Customer Orientation -

Ricon Sales or Service personnel must review the Warranty and Operator Manual with customer to confirm that they understand safe operation of lift. Instruct customer to follow operating instructions without exception.

NOTE: The installing service technician must attach the parking restriction decals to vehicle, if provided with lift. Refer to the Spare Parts chapter for decal locations and part numbers.

III. F10X-SERIES MAINTENANCE AND REPAIR

Regular maintenance of the RICON F10X-Series DOT Public Use Wheelchair and Standee lift is essential for optimum performance, and will reduce the need for repairs. This chapter contains a lift maintenance schedule, plus lift hydraulic and electrical diagrams.

 CAUTION!
This Ricon product is highly specialized. Maintenance and repair work must be performed by a Ricon dealer or qualified service technician, using Ricon replacement parts.

 WARNING!
MODIFYING OR FAILING TO PROPERLY MAINTAIN THIS PRODUCT WILL VOID THE WARRANTY AND MAY RESULT IN UNSAFE OPERATING CONDITIONS.

A. MAINTENANCE SCHEDULE

Climate (weather), lift usage (rate of cycling), and lift age (vehicle mileage) combine to determine the maintenance interval for the lift. Ricon recommends carrying out the inspection items listed in the Maintenance Checklist. Maintenance should be done at the interval prescribed on the appropriate Maintenance Interval Chart.

- ˆ A dedicated entry model lift is installed within a baggage bay, or similar compartment, and is sheltered from the weather.
- ˆ A touring coach (bus) is usually equipped with a dedicated entry lift. Extended mileage occurs between each use of the lift.
- ˆ Refer to the Maintenance Checklist. Copy the checklist for routine use.

TO DETERMINE MAINTENANCE INTERVAL:

Refer to the five Maintenance Interval Charts. Select the one that contains the lift usage (low, normal, high) and climate type (mild, average, severe) that applies to your vehicle. Do the maintenance tasks listed in the Maintenance Checklist at the interval listed above your vehicle type (refer to arrow). Use the mileage or time interval that occurs first.

1. MAINTENANCE INTERVAL CHARTS

Low Usage in Mild Climate:



24,000 miles or 32 weeks	30,000 miles or 36 weeks
Dedicated Entry (protected from environment)	Dedicated Entry – touring (high mileage; low usage)
Low usage (0 - 115 cycles per month)	
Mild climate (light or no snow)	

Low to Normal Usage in Mild to Average Climate:

24,000 miles or 28 weeks		30,000 miles or 32 weeks	
Dedicated Entry (protected from environment)		Dedicated Entry – touring (high mileage; low usage)	
Low (0 – 115 cycles)	Normal usage (116 – 230 cycles per month)	Low (0 – 115 cycles)	Normal usage (116 – 230 cycles per month)
Average climate (light snow)		Mild (light or no snow)	Average climate (light snow)

Low to High Usage in Severe Climate:

12,000 miles or 6 weeks	18,000 miles or 6 weeks
Dedicated Entry (protected from environment)	Dedicated Entry – touring (high mileage; low usage)
Low, normal, and high usage (0 – 230+ cycles per month)	
Severe climate (medium to heavy snow)	

Normal to High Usage in Mild to Average Climate:

24,000 miles or 24 weeks		30,000 miles or 28 weeks	
Dedicated Entry (protected from environment)		Dedicated Entry – touring (high mileage; low usage)	
Normal usage (116 – 230 cycles)	High usage (231+ cycles per month)	Normal usage (116 – 230 cycles)	High usage (231+ cycles per month)
Average climate (light snow)	Mild climate (light or no snow)	Average climate (light snow)	Mild climate (light or no snow)

High Usage in Average Climate:

24,000 miles or 20 weeks	30,000 miles or 24 weeks
Dedicated Entry (protected from environment)	Dedicated Entry – touring (high mileage; low usage)
High usage (231+ cycles per month)	
Average climate (light or no snow)	

B. MAINTENANCE CHECKLIST



**F10X-SERIES
MAINTENANCE CHECKLIST**

Date:	Vehicle #:	Lift serial #:
<i>A checked safety issue requires repairing before the vehicle is returned to service.</i>		
Suggested solvents, cleaners, and lubricants:	Zep Formula 50 R.T.U, part #599A, or equivalent; use to clean decals and platform Zep I.D. Red, part #399C, or equivalent; use to clean carriage assembly Zep PLS, part #497C, or equivalent; use to lubricate carriage assembly Aeroshell grease #22, or equivalent; use to lubricate carriage rollers	
Initial appropriate box ↘	OK	Requires repair
	Repair at next service	Repair before re- turning to service
Platform is clean. Non-skid strips are attached and in good condition.	<input type="checkbox"/>	<input type="checkbox"/>
Platform deploys and lowers to ground.	<input type="checkbox"/>	<input type="checkbox"/>
Check manual pump operation, and hydraulic fluid level. Use Texaco No.1554 aircraft hydraulic fluid (or equivalent U.S. mil spec H5606G oil).	<input type="checkbox"/>	<input type="checkbox"/>
Front roll stop is open (down).	<input type="checkbox"/>	<input type="checkbox"/>

	OK	Requires re- pair	Repair at next service	Repair before re- turning to service
Safety issue Raise platform; verify that front roll stop is closed (up). Verify that it is locked by pulling on rollstop.	<input type="checkbox"/>	<input type="checkbox"/>	<input type="checkbox"/>	<input checked="" type="checkbox"/>
Check all decals. Decals should be readable and securely attached.	<input type="checkbox"/>	<input type="checkbox"/>	<input type="checkbox"/>	<input type="checkbox"/>
Safety issue Bridgeplate is up (vertical).	<input type="checkbox"/>	<input type="checkbox"/>	<input type="checkbox"/>	<input checked="" type="checkbox"/>
Safety issue Raise platform to floor level; bridgeplate must overlap floor 1"– 2".	<input type="checkbox"/>	<input type="checkbox"/>	<input type="checkbox"/>	<input checked="" type="checkbox"/>
Stow platform from floor level. Platform must stow smoothly and completely.	<input type="checkbox"/>	<input type="checkbox"/>	<input type="checkbox"/>	<input type="checkbox"/>
Check hydraulic system (lines, cylinder, and connections) for leaks.	<input type="checkbox"/>	<input type="checkbox"/>	<input type="checkbox"/>	<input type="checkbox"/>
Clean carriage assembly with Zep I.D. Red degreaser.	<input type="checkbox"/>	<input type="checkbox"/>	<input type="checkbox"/>	<input type="checkbox"/>
Inspect and lube four side carriage rollers, and two lifting frame rollers with Aeroshell #22. Remove excess grease.	<input type="checkbox"/>	<input type="checkbox"/>	<input type="checkbox"/>	<input type="checkbox"/>
Inspect and lube four carriage guide rollers (top) with Aeroshell #22. Remove excess grease.	<input type="checkbox"/>	<input type="checkbox"/>	<input type="checkbox"/>	<input type="checkbox"/>
Inspect primary drive chain and carriage drive chain. Adjust, if needed. Lube with Zep PLS lubricating spray.	<input type="checkbox"/>	<input type="checkbox"/>	<input type="checkbox"/>	<input type="checkbox"/>
Inspect 3/4" rod ends and their pivot pins; lube with Zep PLS lubricating spray.	<input type="checkbox"/>	<input type="checkbox"/>	<input type="checkbox"/>	<input type="checkbox"/>
Spray eight lifting frame pins with Zep PLS lubricating spray.	<input type="checkbox"/>	<input type="checkbox"/>	<input type="checkbox"/>	<input type="checkbox"/>
Remove rollstop covers from both sides of platform; clean rollstop pivot points with Zep I.D. Red degreaser. Replace covers.	<input type="checkbox"/>	<input type="checkbox"/>	<input type="checkbox"/>	<input type="checkbox"/>
Stow platform. Lift manual platform release handle and pull platform out completely. Platform must <u>lock in place</u> (cannot be pushed in). Lower platform release handle and push platform in completely. Platform must lock in place (cannot be pulled out).	<input type="checkbox"/>	<input type="checkbox"/>	<input type="checkbox"/>	<input type="checkbox"/>
Verify that TWS is working properly and is correctly adjusted.	<input type="checkbox"/>	<input type="checkbox"/>	<input type="checkbox"/>	<input type="checkbox"/>
NOTES:	Print name: _____			
	Signature: _____			

C. HYDRAULIC CIRCUIT DIAGRAM

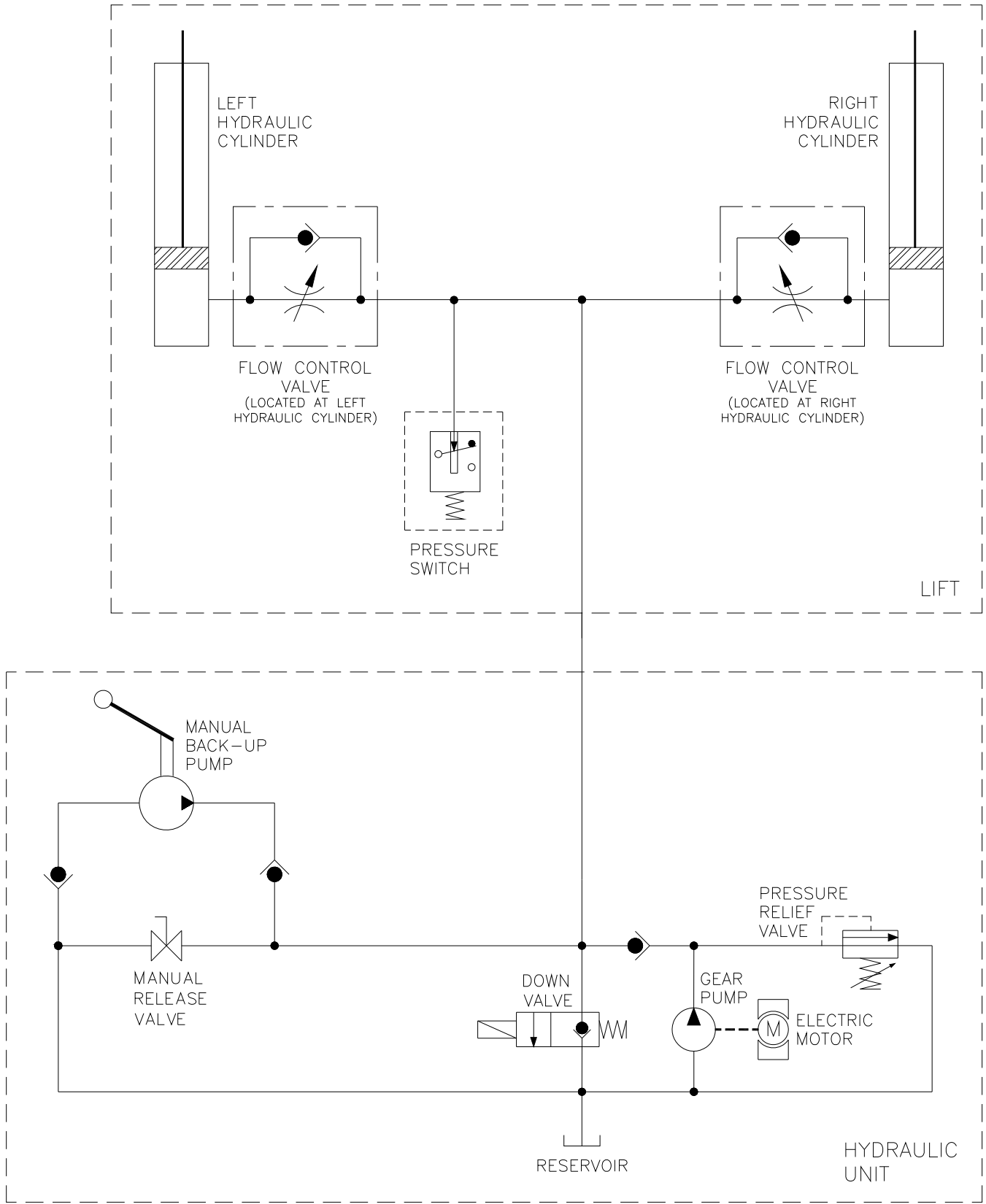

FIGURE 3-12: F10X-SERIES HYDRAULIC CIRCUIT

D. ELECTRICAL WIRING DIAGRAM

1. DIAGRAM LEGEND

a. Wire Color Codes

TABLE 3-1: WIRE COLOR CODES			
LETTER	COLOR	LETTER	COLOR
BLK	Black	RED	Red
BLU	Blue	VIO	Violet
BRN	Brown	GRY	Gray
GRN	Green	WHT	White
ORG	Orange	YEL	Yellow
END OF TABLE			

b. Electrical Connector Description

Refer to **Figure 3-13**. The standard electrical connectors used by Ricon are Molex .062" Series. These connectors have terminal numbers molded onto the back. Use these numbers and colors to identify all wires.

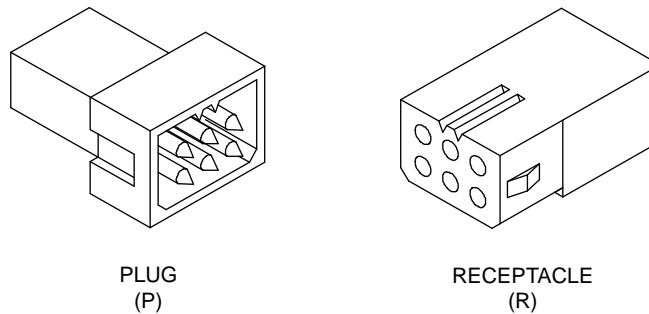

FIGURE 3-13: MOLEX CONNECTORS

RSM0005600

c. Diagram Labels

TABLE 3-5: DIAGRAM LABELS		
Diagram Label	Definition	Command/Description
12V	12 Volts	Circuit current rating is also given
DC	Door Close	Direct Command
DO	Door Open	Direct Command
DOE	Door Open Enable	From Door Open Cut-off switch.
DWN	Pump Down	Used by OUT and DOWN
DWNA	Down Attempt	Must be enabled
FAST		Signal to speedup valve for UP and DOWN
GND	Ground	
OUTA	Out Attempt	Out must be enabled
SDA	System Deploy Attempt	DO followed by OUT
SSA	System Store Attempt	IN followed by DC
UP	Pump Up	Used by UP and IN
UPA	Up Attempt	Up must be enabled
END OF TABLE		

d. **Electrical Symbols**

Figure 3-14 shows standard symbols used in the electrical wiring diagram.

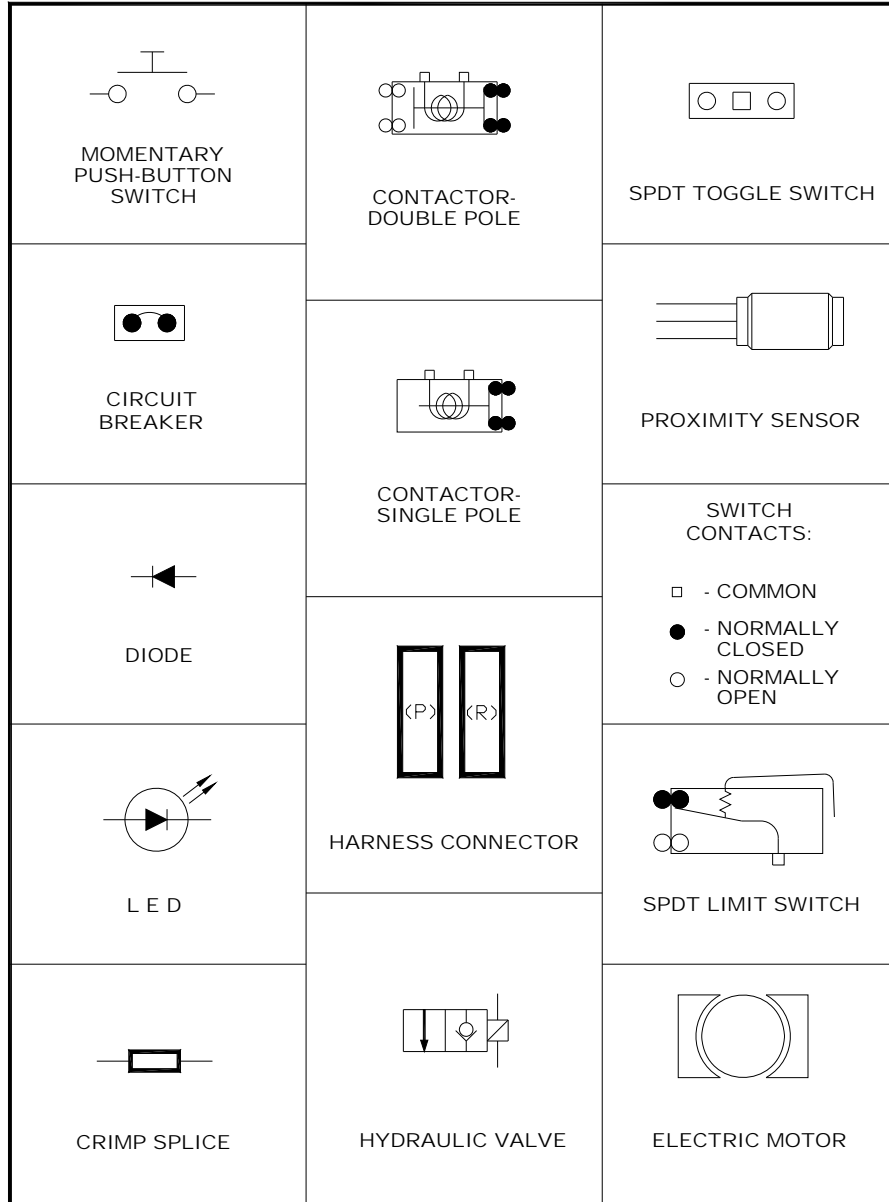

FIGURE 3-14: DIAGRAM SYMBOLS

e. **WIRING DIAGRAM**

Refer to Figures 3-15-1 and 3-15-2 for the F10X-Series wiring diagram.

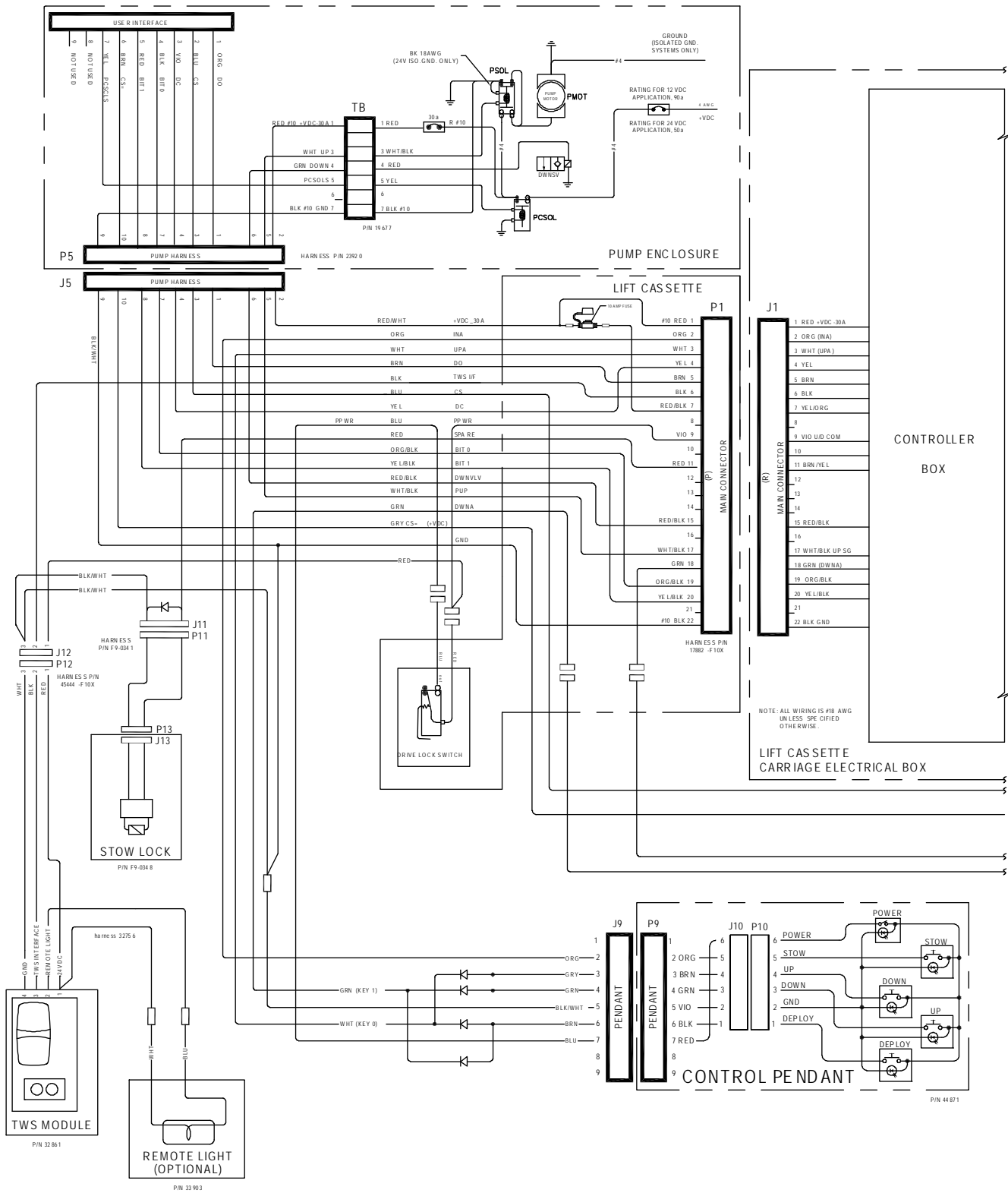

FIGURE 3-15-1: F10X-SERIES WIRING DIAGRAM (SHEET 1 OF 2)

RSM0032800

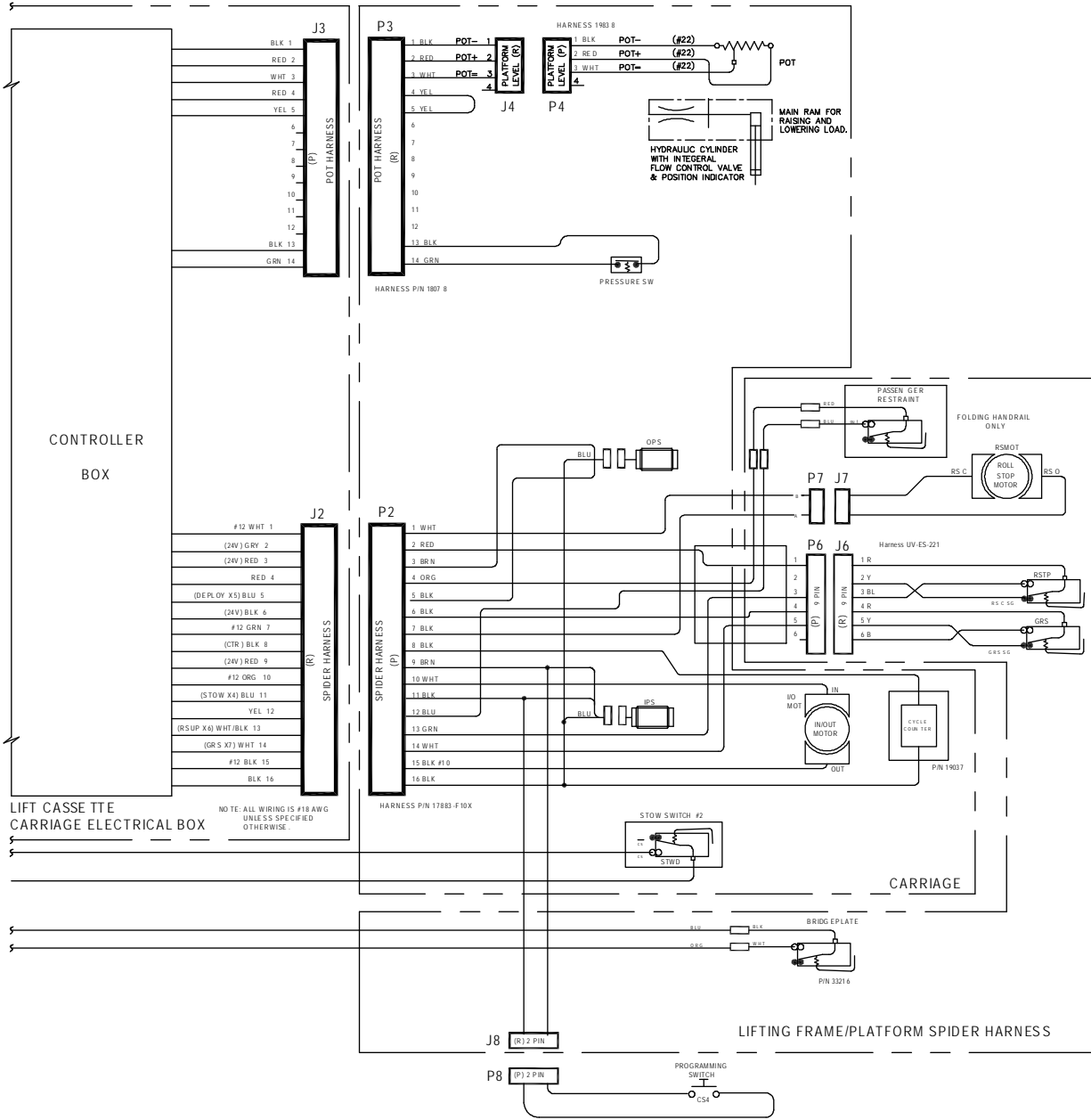

FIGURE 3-15-2: F10X-SERIES WIRING DIAGRAM (SHEET 2 OF 2)

RSM0032900

This page intentionally left blank.

IV. F10X-SERIES COMPONENT SERVICE

This chapter provides instructions for major system repairs, system adjustments, and parts replacement on the RICON F10X-Series DOT Public Use Wheelchair and Standee lift.

- This chapter provides information for installations that are either right-handed or left-handed. As a result, some manual illustrations may appear reversed when compared to your installation.
- Maintain the lift at its highest level of performance by doing the required maintenance. Ricon recommends a thorough inspection every six months.
- A specific repair task might not require completion of all listed steps in a procedure.
- Additional component illustrations are available in the Spare Parts chapter.

A. GENERAL SAFETY PRECAUTIONS

 WARNING!
<p>THIS RICON PRODUCT IS HIGHLY SPECIALIZED. A RICON DEALER OR QUALIFIED SERVICE TECHNICIAN MUST PERFORM MAINTENANCE AND REPAIRS USING RICON REPLACEMENT PARTS. MODIFYING OR NOT PROPERLY MAINTAINING THIS PRODUCT WILL VOID THE WARRANTY, AND MAY RESULT IN UNSAFE OPERATING CONDITIONS.</p>

The following general safety precautions must be followed during service and maintenance:

- Do not attempt maintenance, repairs, or adjustments without the presence of a person capable of rendering first-aid.
- Take notice of all injuries, regardless of how slight. Administer first aid or seek medical attention immediately.
- Wear protective eye shields and appropriate clothing at all times.
- Work in a properly ventilated area. Do not smoke, or use an open flame, near the battery.
- Exercise caution when operating lift to avoid injury. Be certain that hands, feet, legs and clothing are not in path of the platform as it moves.
- Be cautious when using metallic (conductive) tools near the battery, or heavy gauge wires.
- If battery acid contacts skin, wash area immediately with soap and water.
- Check under vehicle before drilling or cutting to avoid damage to the frame, subframe members, wiring, hydraulic lines, etc.
- Thoroughly understand the operating instructions before attempting to operate lift.
- Keep others clear during lift operation.

 WARNING
<ul style="list-style-type: none"> ▪ WEAR PROTECTIVE CLOTHING AND EYE PROTECTION AT ALL TIMES. BATTERIES CONTAIN ACID THAT CAN BURN. IF ACID COMES INTO CONTACT WITH SKIN, IMMEDIATELY FLUSH AFFECTED AREA WITH WATER AND WASH WITH SOAP. ▪ WORK IN A PROPERLY VENTILATED AREA. DO NOT SMOKE OR USE AN OPEN FLAME IN THE VICINITY OF BATTERY. ▪ DO NOT LAY ANYTHING METALLIC ON TOP OF BATTERY.

 WARNING
<p>THE SERVICE ACCESS PANEL IS HINGED ALONG THE REAR EDGE AND SHOULD BE HELD UP WHILE REMOVING THE RETAINING SCREWS AT THE FRONT EDGE. THIS WILL PREVENT PANEL FROM FALLING AND CAUSING INJURY OR DAMAGE.</p>

B. LIFT ACCESS FOR SERVICE

Refer to **Figure 4-1**. Platform and lifting frame components can be accessed by deploying the travelling frame. Some components within the carriage can be accessed from the front of the carriage when it is deployed. Other components within the carriage, or inside the enclosure, must be accessed from the top of the enclosure. Some of these components may require repositioning of the carriage to allow access through the openings between the enclosure supports. These four supports, which tie the top flanges of the side channels together, are fastened in place. They can be removed for greater access.

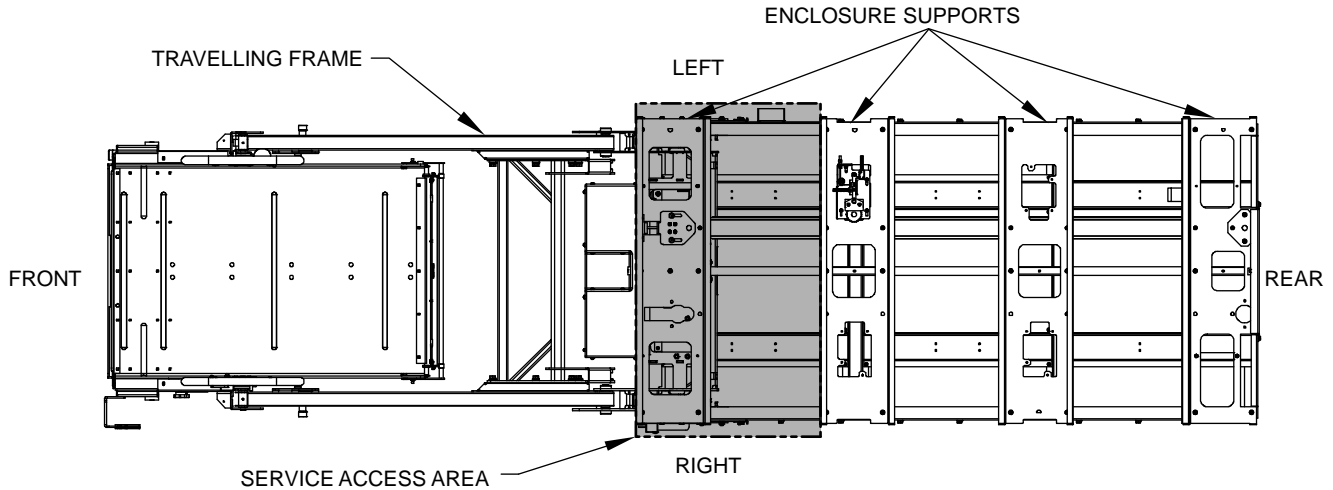

RSM0033001

FIGURE 4-1: SERVICE ACCESS AREA (TOP VIEW)

C. TRAVELLING FRAME

Refer to **Figure 4-2**. The platform, lifting frame, and carriage are referred to as a “travelling frame” when assembled as a unit. This assembly locates on two rails inside the enclosure, and is able to move in and out of the enclosure.

The travelling frame should be removed from the enclosure by first separating the platform from the lifting frame, and then separating the lifting frame from the carriage. The carriage is then removed from the enclosure. This is the preferred approach because it avoids having to cope with the heavy weight of the assembled travelling frame.

Procedures describing the removal of the platform, lifting frame, and carriage are in the following sections.

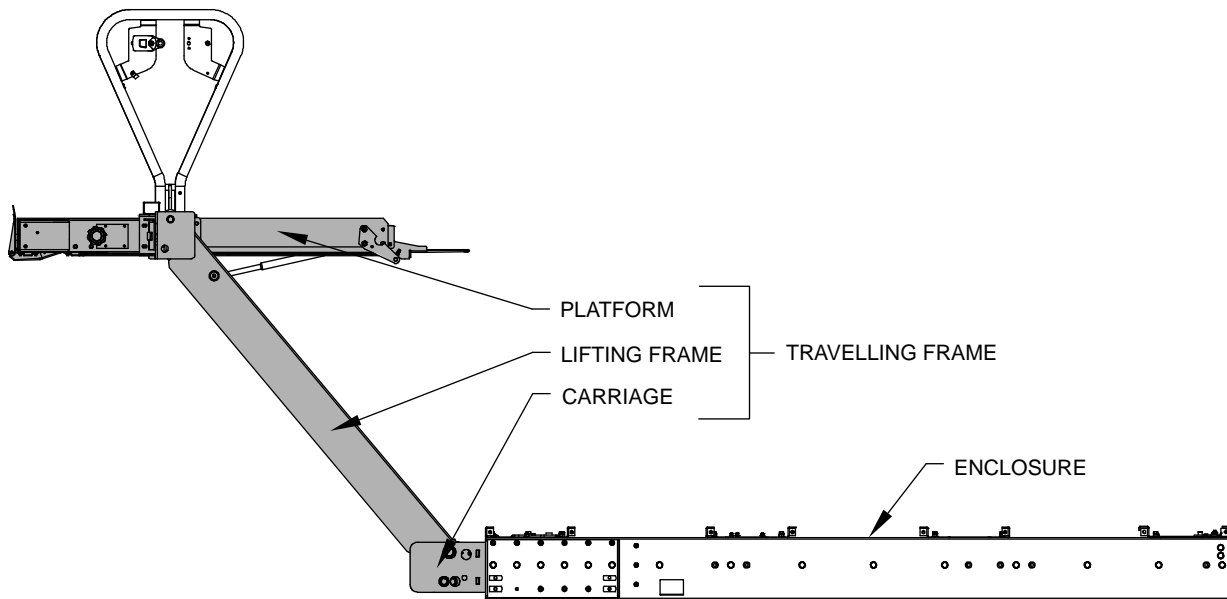

RSM0033101

FIGURE 4-2: TRAVELLING FRAME

1. ROLLSTOP MAINTENANCE

a. Rollstop Lubrication

- 1) Deploy platform using control pendant (DEPLOY) and then support.

 WARNING!
<ul style="list-style-type: none"> WEAR PROTECTIVE CLOTHING AND EYE PROTECTION AT ALL TIMES. BATTERIES CONTAIN ACID THAT CAN BURN. IF ACID COMES INTO CONTACT WITH SKIN, IMMEDIATELY FLUSH AFFECTED AREA WITH WATER AND WASH WITH SOAP. WORK IN A PROPERLY VENTILATED AREA. DO NOT SMOKE OR USE AN OPEN FLAME IN THE VICINITY OF BATTERY. DO NOT LAY ANYTHING METALLIC ON TOP OF BATTERY.

- 2) Disconnect positive battery cable at vehicle battery compartment.
- 3) Refer to **Figure 4-3**. Remove left and right rollstop covers (four screws and washers, each side).

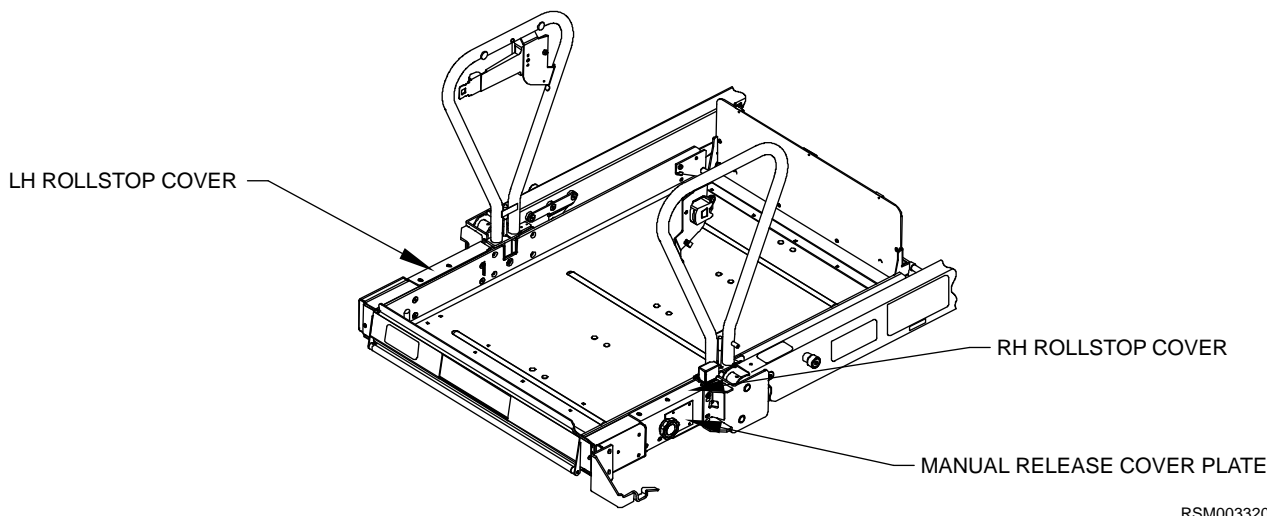
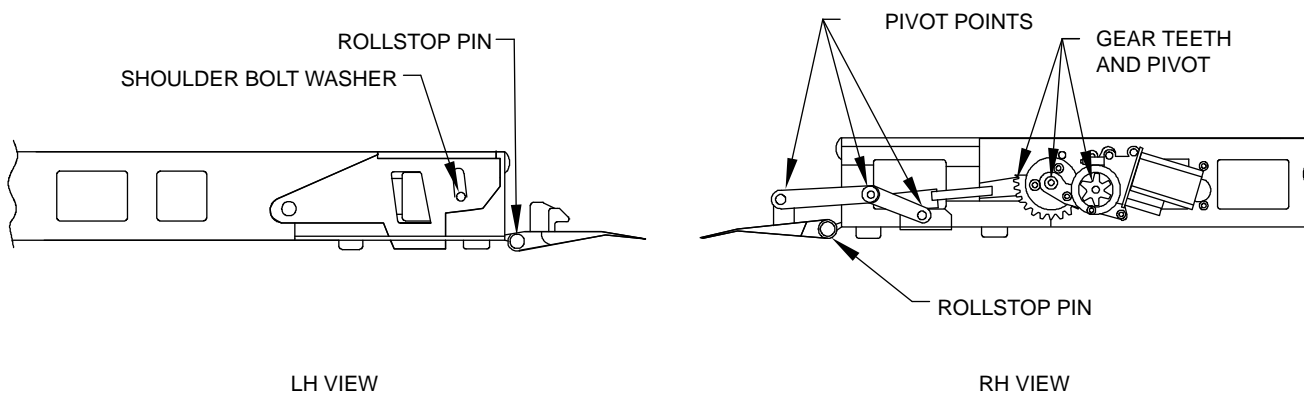

FIGURE 4-3: ACCESS COVERS FOR ROLLSTOP MECHANISM

 CAUTION!
<p>The manual rollstop control knob is made from a brittle material. Handle carefully.</p>

- 4) Use a 1/8 in. (3mm) drift punch to remove retaining pin from manual rollstop control knob. Remove knob.
- 5) Remove right rollstop actuator bracket and left rollstop release bracket.
- 6) Refer to **Figure 4-4**. Lubricate rollstop pivot points and gears (both sides of platform) using light grease (ZEP PLS, P/N 497C, Curtisol® Red Grease P/N 88167, or equivalent). Wipe off excess grease.



RSM0033300

FIGURE 4-4: ROLLSTOP LUBRICATION POINTS

- 7) Reinstall right rollstop actuator bracket and left rollstop release bracket.
- 8) Reinstall right and left rollstop covers.
- 9) Reinstall manual rollstop control knob.
- 10) Reconnect positive battery cable at vehicle battery compartment.

b. **“Rollstop Open” Switch Adjustment**

NOTE: Refer to Electrical Controls section if replacement of rollstop “Open” switch is necessary.

- 1) Deploy platform using control pendant (Deploy), and then support.

 WARNING!
<ul style="list-style-type: none"> • WEAR PROTECTIVE CLOTHING AND EYE PROTECTION AT ALL TIMES. BATTERIES CONTAIN ACID THAT CAN BURN. IF ACID COMES INTO CONTACT WITH SKIN, IMMEDIATELY FLUSH AFFECTED AREA WITH WATER AND WASH WITH SOAP. • WORK IN A PROPERLY VENTILATED AREA. DO NOT SMOKE OR USE AN OPEN FLAME IN THE VICINITY OF BATTERY. • DO NOT LAY ANYTHING METALLIC ON TOP OF BATTERY.

- 2) Disconnect positive battery cable at vehicle battery compartment.
- 3) Remove left rollstop cover (four screws and washers).
- 4) Remove left rollstop release bracket.
- 5) Refer to **Figure 4-5**. Loosen actuator cam retaining screws, and pivot actuator cam away from switch activating wheel (roller).

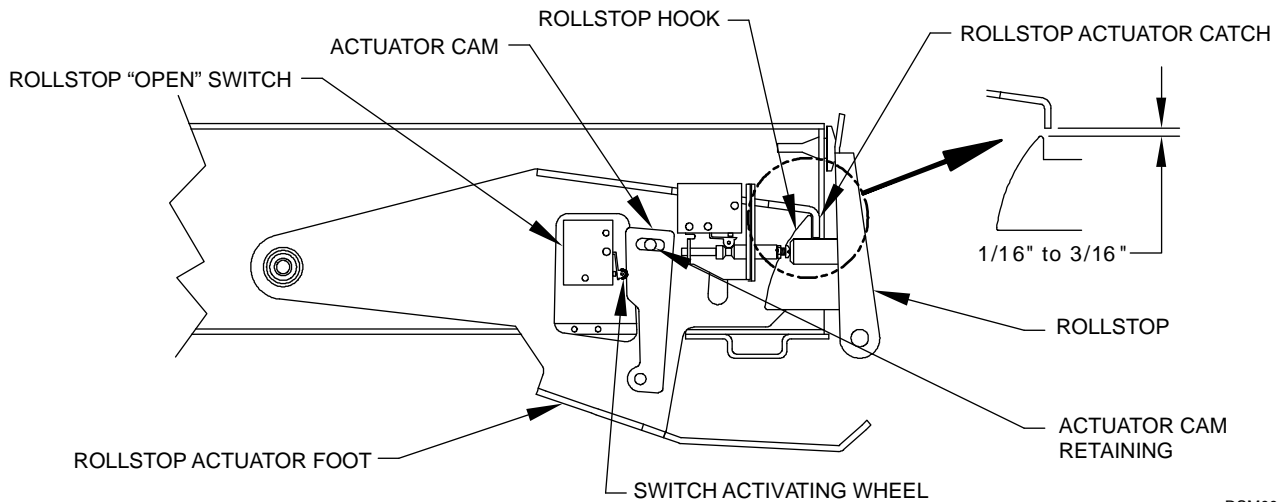

RSM0033400

FIGURE 4-5: ROLLSTOP ACTUATION COMPONENTS

- 6) Manually raise rollstop actuator foot until its catch has a clearance above rollstop hook of 1/16 in. to 3/16 in. (1.6mm to 4.8mm) Hold foot at this gap.
- 7) Move cam toward switch activating wheel until a faint click is heard from the Rollstop Open switch. The change of state is also marked by the switch contact resistance becoming zero (short) when measured at pins four and five of the rollstop switch harness. Tighten the cam retaining screws.
- 8) Release rollstop actuator foot.
- 9) Re-check adjustment by raising actuator foot and observing the click or resistance change. Actuation must occur as described above. Move cam away from switch if switch does not change state. Repeat, as necessary.
- 10) Re-install left rollstop cover and left rollstop release bracket.
- 11) Reconnect the positive battery cable at the vehicle battery compartment.

c. **“Rollstop Closed” Position Adjustment**

- 1) Deploy platform using control pendant (OUT), and then support.

**WARNING!**

- WEAR PROTECTIVE CLOTHING AND EYE PROTECTION AT ALL TIMES. BATTERIES CONTAIN ACID THAT CAN BURN. IF ACID COMES INTO CONTACT WITH SKIN, IMMEDIATELY FLUSH AFFECTED AREA WITH WATER AND WASH WITH SOAP.
- WORK IN A PROPERLY VENTILATED AREA. DO NOT SMOKE OR USE AN OPEN FLAME IN THE VICINITY OF BATTERY.
- DO NOT LAY ANYTHING METALLIC ON TOP OF BATTERY.

- 2) Disconnect positive battery cable at vehicle battery compartment.
- 3) Remove right rollstop cover (four screws and washers) and cover spacers.

**CAUTION!**

The manual rollstop control knob is made from a brittle material. Handle carefully.

- 4) Use a 1/8 in. (3mm) punch to remove retaining pin from manual rollstop control knob. Remove control knob.
- 5) Remove right rollstop actuator bracket.
- 6) Refer to **Figure 4-6**. Loosen jam-nut on link and adjust its length by turning the threaded union. Adjust link so that rollstop closes to within 1/32 in. (0.8mm) of rubber bumper (that rollstop contacts). Rotating the threaded union counterclockwise (viewed from rollstop) shortens the link, and turning it clockwise lengthens it.

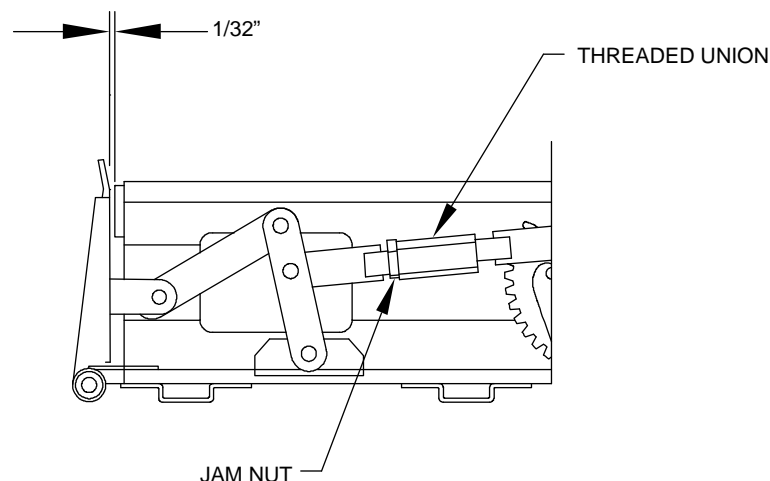

RSM0033500

FIGURE 4-6: CLOSED ROLLSTOP ADJUSTMENT

- 7) Reinstall right rollstop cover and manual rollstop control knob.
- 8) Reconnect positive battery cable at vehicle battery compartment.

d. **“Rollstop Closed” Switch Adjustment**

Refer to Electrical Controls section if replacing a Rollstop Closed switch.

- 1) Deploy platform using control pendant (DEPLOY), and then support.

**WARNING!**

- WEAR PROTECTIVE CLOTHING AND EYE PROTECTION AT ALL TIMES. BATTERIES CONTAIN ACID THAT CAN BURN. IF ACID COMES INTO CONTACT WITH SKIN, IMMEDIATELY FLUSH AFFECTED AREA WITH WATER AND WASH WITH SOAP.
- WORK IN A PROPERLY VENTILATED AREA. DO NOT SMOKE OR USE AN OPEN FLAME IN THE VICINITY OF BATTERY.
- DO NOT LAY ANYTHING METALLIC ON TOP OF BATTERY.

- 2) Disconnect positive battery cable at vehicle battery compartment.
- 3) Remove left rollstop cover (four screws and washers).
- 4) Remove left rollstop release bracket.
- 5) Have an assistant hold rollstop actuator foot up (refer back to **Figure 4-4**). Open rollstop with manual control knob (other hand assisting movement of rollstop).
- 6) Refer to **Figure 4-7**. Adjust "Closed" switch by loosening jam-nut and turning adjustment screw that protrudes from end of plunger. The enlarged view shows plunger position when rollstop is open. The plunger should move to position shown in upper view when rollstop is closed. Adjust screw so that switch roller is on outside diameter of plunger when rollstop is closed. Retighten jam-nut.

NOTE: The plunger may need to be held with a small pair of pliers to turn screw. Do not scratch outside surface of plunger with pliers; this could cause plunger to seize in its bore.

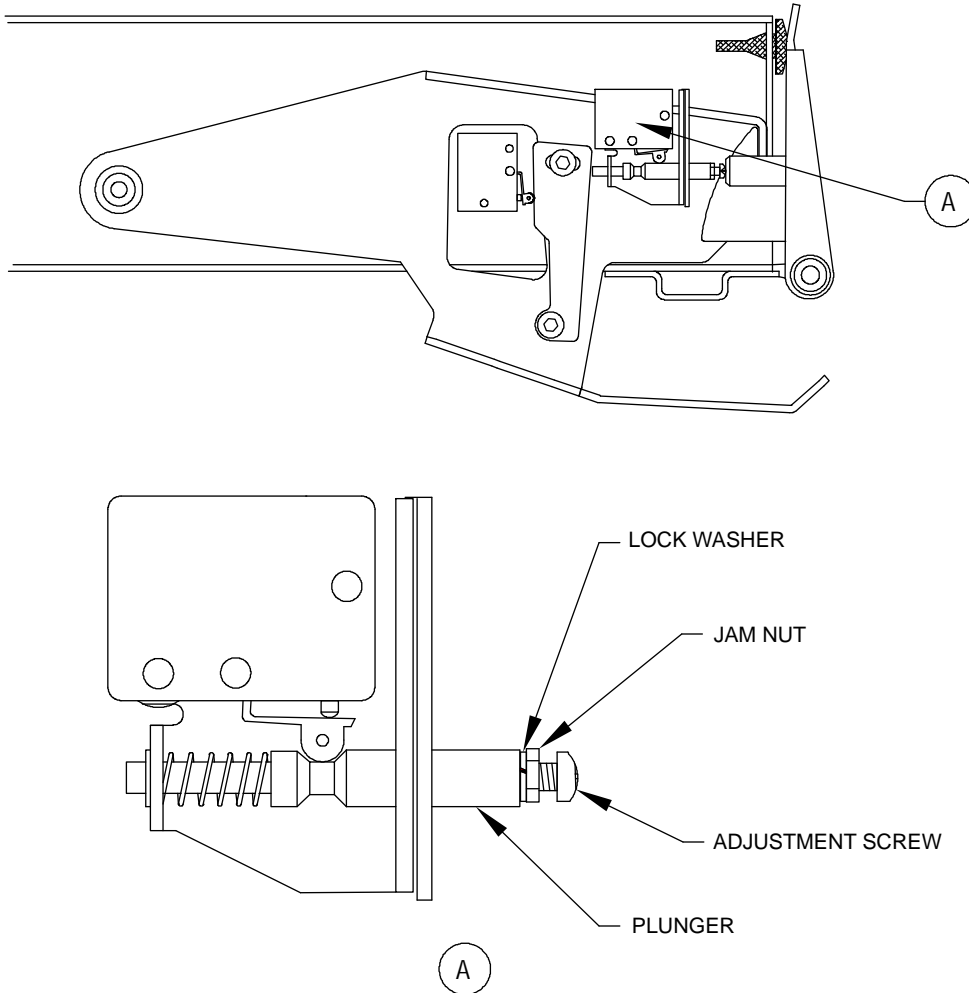

RSM0033600

FIGURE 4-7: "CLOSED" SWITCH ADJUSTMENT

- 7) Close rollstop.
- 8) Re-install left rollstop cover and left rollstop release bracket.
- 9) Reconnect positive battery cable at vehicle battery compartment.

2. BRIDGEPLATE MAINTENANCE

a. Bridgeplate Lubrication

- 1) Deploy platform using control pendant (DEPLOY) and support.

 WARNING!
<ul style="list-style-type: none"> • WEAR PROTECTIVE CLOTHING AND EYE PROTECTION AT ALL TIMES. BATTERIES CONTAIN ACID THAT CAN BURN. IF ACID COMES INTO CONTACT WITH SKIN, IMMEDIATELY FLUSH AFFECTED AREA WITH WATER AND WASH WITH SOAP. • WORK IN A PROPERLY VENTILATED AREA. DO NOT SMOKE OR USE AN OPEN FLAME IN THE VICINITY OF BATTERY. • DO NOT LAY ANYTHING METALLIC ON TOP OF BATTERY.

- 2) Disconnect positive battery cable at vehicle battery compartment.
- 3) Refer to **Figure 4-8**. Lubricate the points indicated in the figure with light grease (ZEP PLS, P/N 497C, Curtisol® Red Grease P/N 88167, or equivalent). Wipe off excess grease. Repeat for other side of bridgeplate.

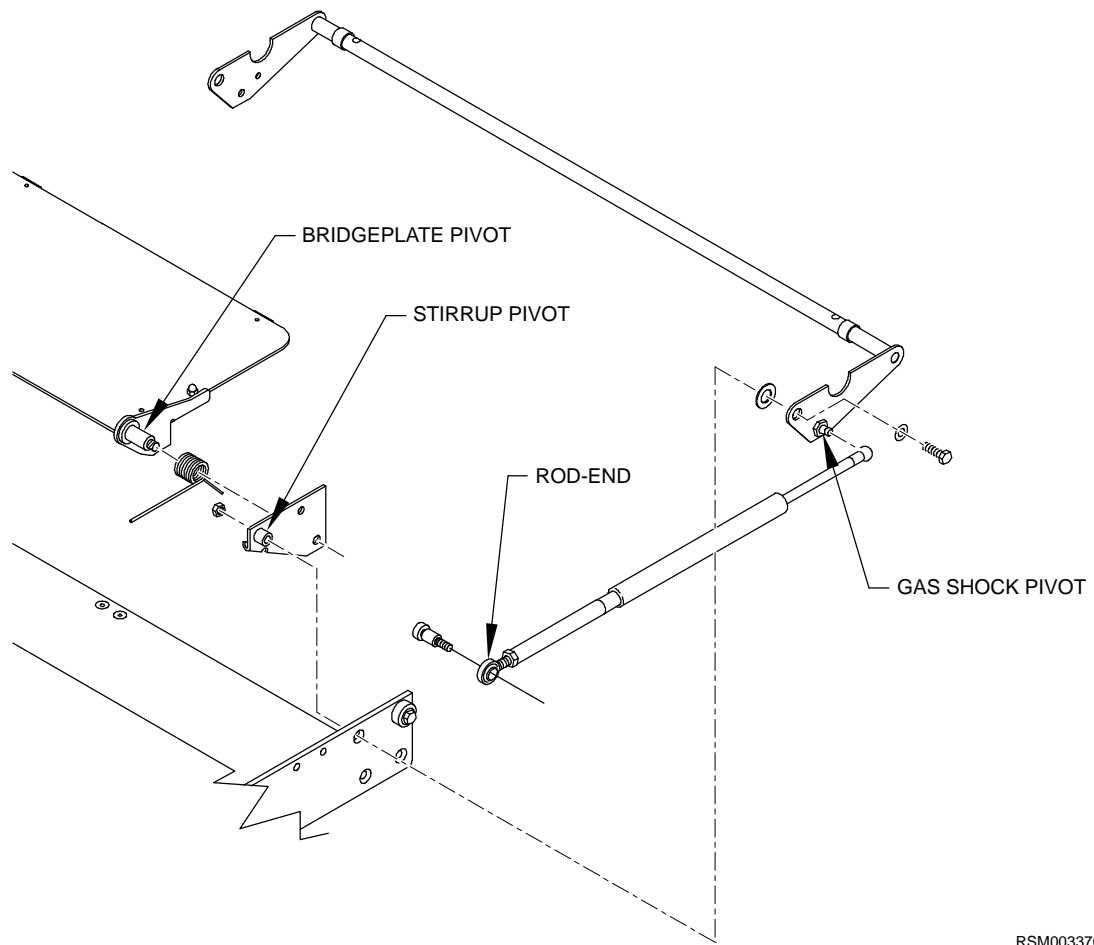

RSM0033700

FIGURE 4-8: BRIDGEPLATE LUBRICATION POINTS

- 4) Reconnect positive battery cable at vehicle battery compartment.

b. Bridgeplate Actuator Rod Adjustment

Two actuator rods unfold the bridgeplate. The rod lengths control the angle of the bridgeplate relative to the platform. Adjust actuator rods so bridgeplate is fully unfolded when platform arrives at floor height. Refer to the Bridgeplate Actuator Rod Adjustment section in Chapter II for an adjustment procedure.

3. CARRIAGE AND LIFTING FRAME MAINTENANCE

Refer to **Figure 4-9**. There are two large carriage rollers on each side of carriage, and four small guide rollers on top. There are also two additional rollers on the forward end of lifting frame. These ten rollers require lubrication on a periodic basis, dependant upon usage and climate. Refer to the Maintenance Checklist in the Service chapter.

The large carriage rollers carry the weight of the travelling frame plus the platform occupant. Each has a grease fitting on its inboard end. Lubricate fittings with Aeroshell #22, or equivalent.

The small carriage guide rollers keep the carriage aligned with the enclosure.

The two lifting frame rollers provide additional alignment between the travelling frame and enclosure. Each has a grease fitting at its inner end. Remove the lifting frame rollers to gain access to their grease fittings. Lubricate with Aeroshell #22, or equivalent. Replace rollers on lifting frame.

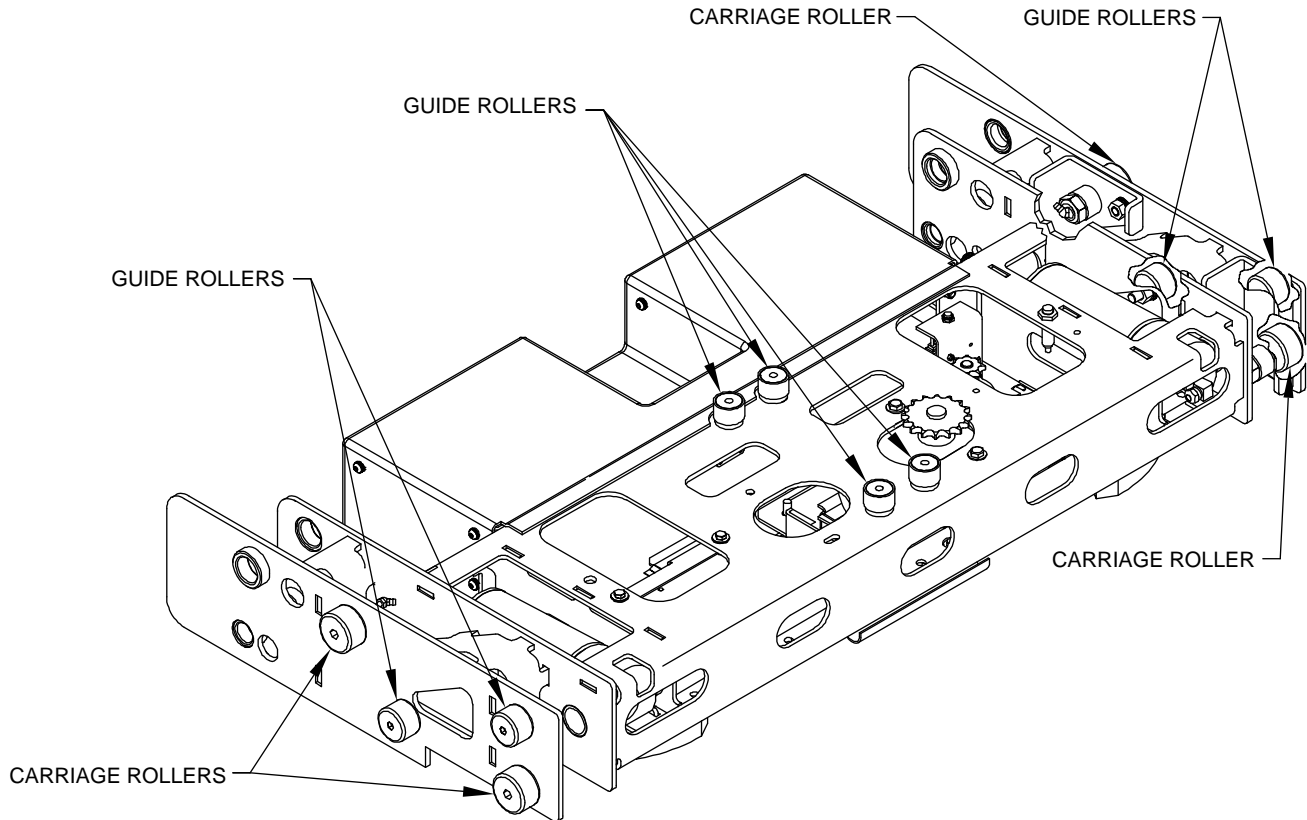

RSM0033800

**FIGURE 4-9: CARRIAGE ROLLERS AND GUIDE ROLLERS
(grease fittings indicated with arrows)**

4. PLATFORM REMOVAL

Refer to the end of this section for re-installation notes.

- a. Deploy platform using control pendant (DEPLOY).
- b. Refer to **Figure 4-10**. Remove lifting arm and lower arm set screws at left and right sides of platform.

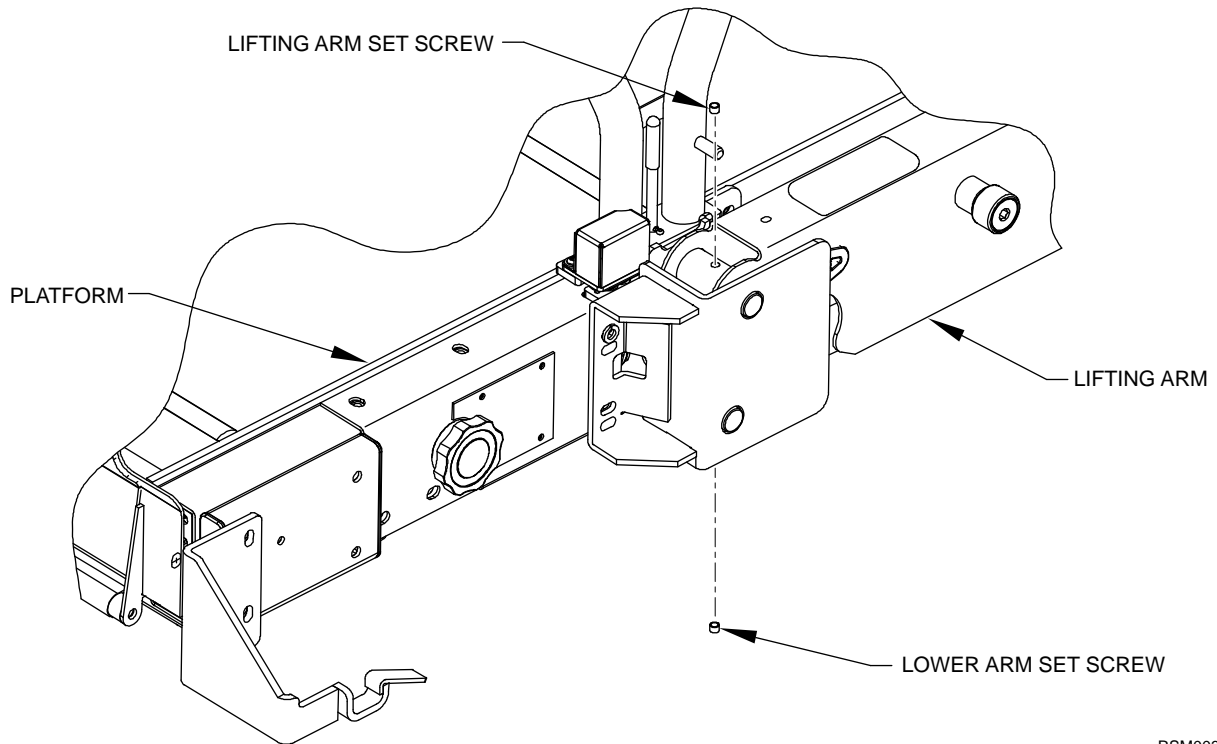

RSM0033900

FIGURE 4-10: LIFTING FRAME AND LOWER ARM SET SCREWS

- c. Raise platform to vehicle floor height using control pendant (UP), and then support.

 WARNING!
<ul style="list-style-type: none"> • WEAR PROTECTIVE CLOTHING AND EYE PROTECTION AT ALL TIMES. BATTERIES CONTAIN ACID THAT CAN BURN. IF ACID COMES INTO CONTACT WITH SKIN, IMMEDIATELY FLUSH AFFECTED AREA WITH WATER AND WASH WITH SOAP. • WORK IN A PROPERLY VENTILATED AREA. DO NOT SMOKE OR USE AN OPEN FLAME IN THE VICINITY OF BATTERY. • DO NOT LAY ANYTHING METALLIC ON TOP OF BATTERY.

- d. Disconnect positive battery cable at vehicle battery compartment.
- e. Refer to **Figure 4-11**. Locate right-side actuator rod assembly (right side of platform, at top of lifting frame). Loosen rod-end jam-nut.

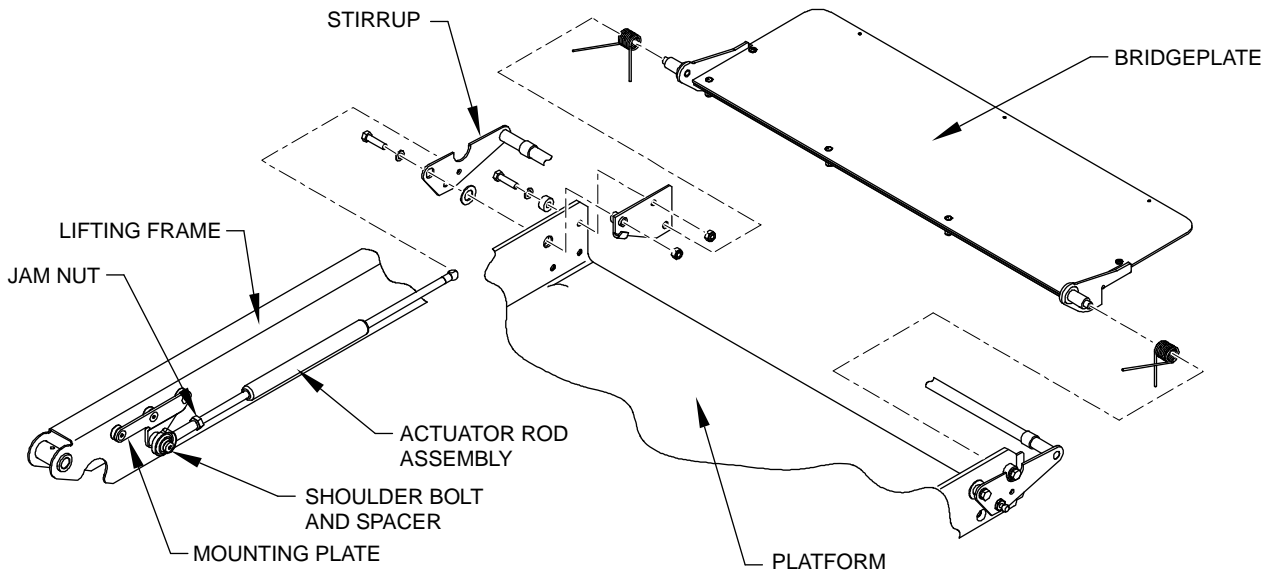

RSM0034000

FIGURE 4-11: BRIDGEPLATE ACTUATOR ROD REMOVAL

- f. Remove shoulder bolt that fastens actuator rod-end to mounting plate (on lifting frame arm).
- g. Repeat for left-side actuator rod assembly.
- h. Fold bridgeplate onto lift platform, and rotate actuator arms parallel to platform. Secure bridgeplate and actuator arms to platform with cable ties.
- i. Remove right and left rollstop side covers (four screws and washers) and spacers.
- j. Disconnect electrical harness at both sides of platform (rollstop switch at left side; rollstop motor at right). Cut black and white leads to the safety belt switch; cut leads adjacent to factory-crimped butt splices. Remove cable ties that hold harness in place. Remove rollstop switch and rollstop motor connectors from harness.

NOTE: Record connector pin position for each wire. This data will be used for platform re-installation; refer to wiring diagrams in Chapter 3. Crimp bridgeplate switch leads to harness with new butt splices when re-installing.

⚠ CAUTION!

Double-check the support holding platform up before removing lower mounting pins. The platform will be free to rotate when pins are removed.

Do not damage outside surface of pins during removal. A pin should be replaced if its outer surface is pitted or grooved after removal.

- k. Refer to **Figure 4-12**. Remove lower platform mounting pins from platform mounting brackets, and drop lower arms.

NOTE: The platform mounting pins can be removed by placing a small pry-bar between the outside of platform and inward end of pin. Push pin outward until it is flush with bracket, and then grasp other end of pin and pull out.

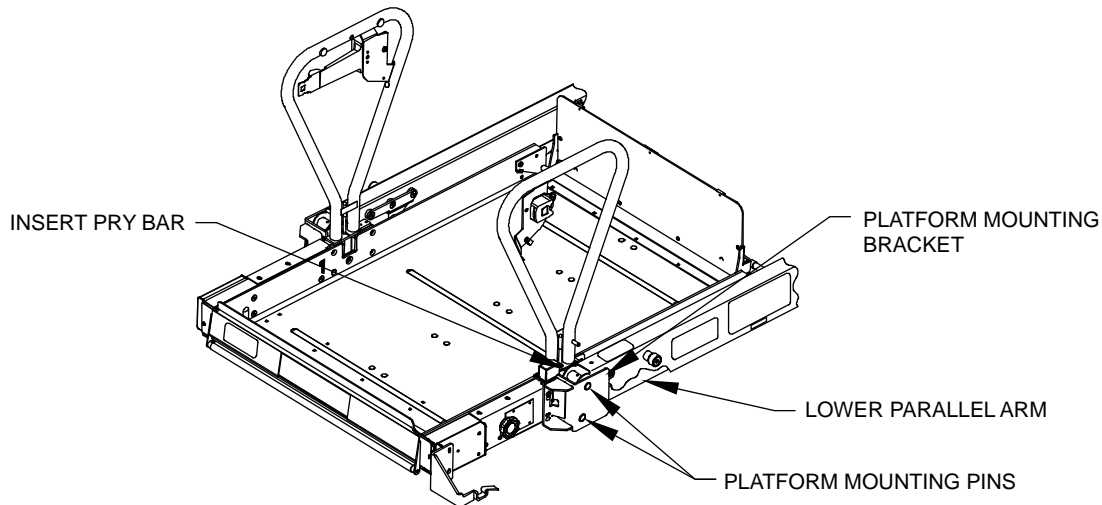

RSM0034100

FIGURE 4-12: PLATFORM SEPARATION FROM LIFTING FRAME

- l. Pass free ends of electrical harness through platform mounting brackets.
- m. Remove upper pins from platform mounting brackets. Remove pins in same manner as lower pins.
- n. Remove platform from lifting frame.
- o. Separate platform from lifting frame.
- p. Examine eight bushings installed in platform mounting brackets for excessive wear or damage.
- q. Platform Re-installation:
Perform re-installation by reversing the removal steps, with the following considerations. Verify that platform mounting bracket holes and lifting frame holes are properly aligned, and then drive mounting pins in place using a soft, heavy hammer. Use a thread locker (such as loc-TITE® blue or omniFIT® blue) when reinstalling setscrews.

5. LIFTING FRAME REMOVAL

The following procedure describes removal of lifting frame **after** platform has been removed. Refer to Travelling Frame section at beginning of chapter for relevant notes. Refer to end of this section for re-installation notes.

- a. Refer to the Platform Removal section and remove platform.
- b. Refer to **Figure 4-13**. Raise lifting frame with manual backup pump until the rod end pivot pin is aligned with the access hole in side of carriage. Support lifting frame at this height.

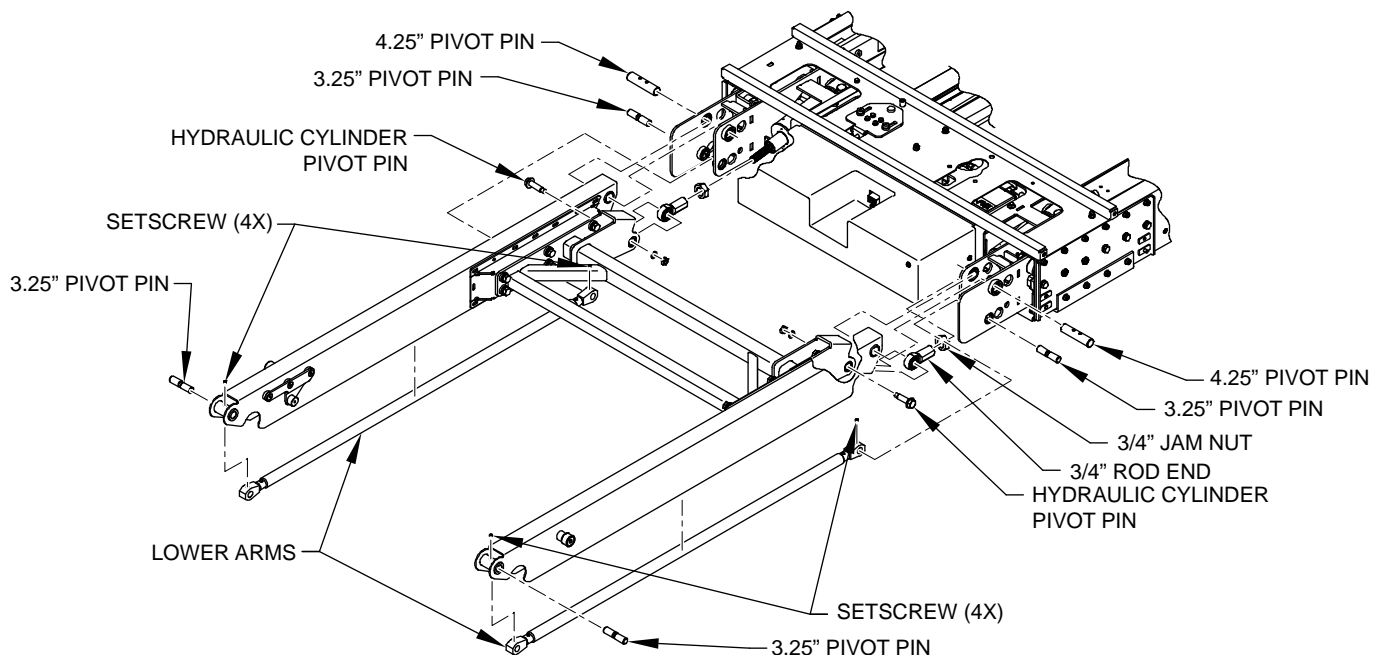

RSM0034200

FIGURE 4-13: LIFTING FRAME COMPONENTS

- c. Refer to **Figure 4-13**. Remove screw and washer securing left and right rod end pivot pins. Remove each rod end pivot pin from lifting frame by extracting through hole in side of carriage.

**CAUTION!**

Do not damage outside surface of pins during removal. A pin should be replaced if its outer surface is pitted or grooved.

- d. Remove four locking setscrews that secure the four lifting frame pivot pins. Remove lower lifting frame pivot pins from carriage, and remove lower arms.
- e. Remove upper lifting frame pivot pins, and separate lifting frame from carriage.
- f. Examine the four lifting frame pivot pins for excessive wear or damage. Examine the eight bushings installed in the carriage and the four bushings installed in the lifting frame. Also, examine the eight bushings installed in the lower arms.

Lifting Frame Re-installation:

Perform re-installation by reversing removal steps, with the following considerations. Verify that carriage holes and lifting frame holes are properly aligned, and then drive pivot pins in place using a soft, heavy hammer. Use a thread locker (such as loc-TITE® blue or omniFIT® blue) when installing new setscrews and locking screws.

6. CARRIAGE REMOVAL

The following procedure describes removal of carriage **after** platform and lifting frame have been removed. Refer to Travelling Frame section at beginning of chapter for relevant notes. Refer to the end of this section for reinstallation notes.

- a. Deploy platform using control pendant (DEPLOY).
- b. Refer to Platform Removal section and remove platform.
- c. Refer to Lifting Frame Removal section and remove lifting frame.
- d. Verify that positive battery cable is disconnected.
- e. Refer to **Figure 4-14**. The carriage stop block mounting screws are accessible from front of enclosure. Remove screws and stop blocks.

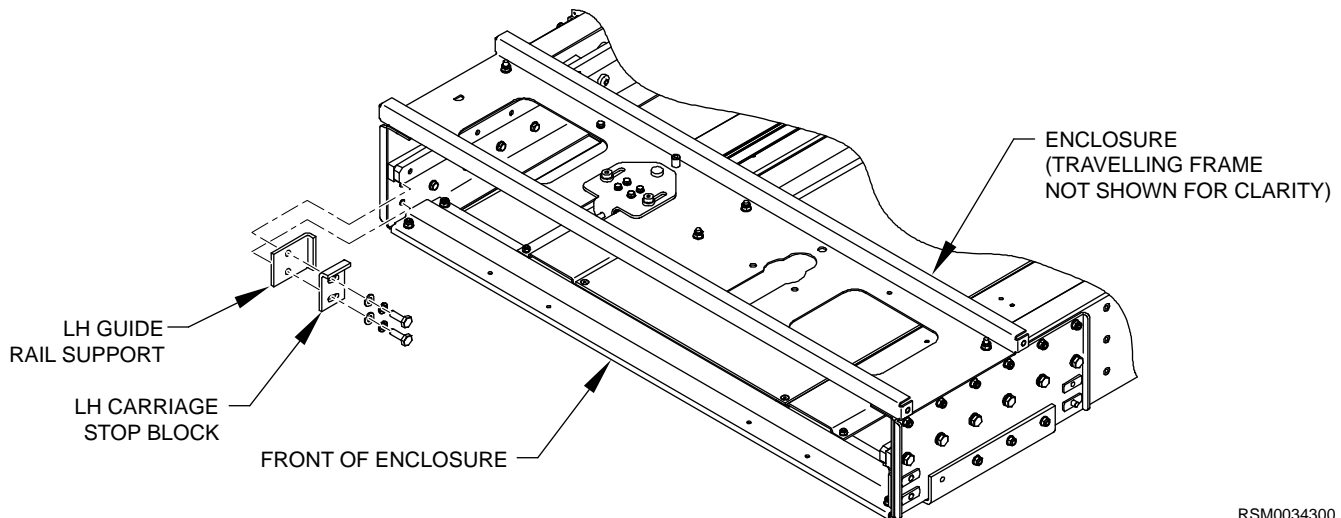

RSM0034300

FIGURE 4-14: CARRIAGE STOP BLOCK LOCATIONS

- f. Refer to **Figure 4-17**. Unlock the carriage drive chain by pulling the manual platform release handle upward (handle is located near hydraulic pump assembly).
- g. Remove two nuts fastening hose retaining clamp (located at bottom, rear-center of carriage).

NOTE: The following step will spill hydraulic fluid; have dry rags on hand.

- h. Refer to **Figure 4-15**. Disconnect hydraulic hose from quick-disconnect.

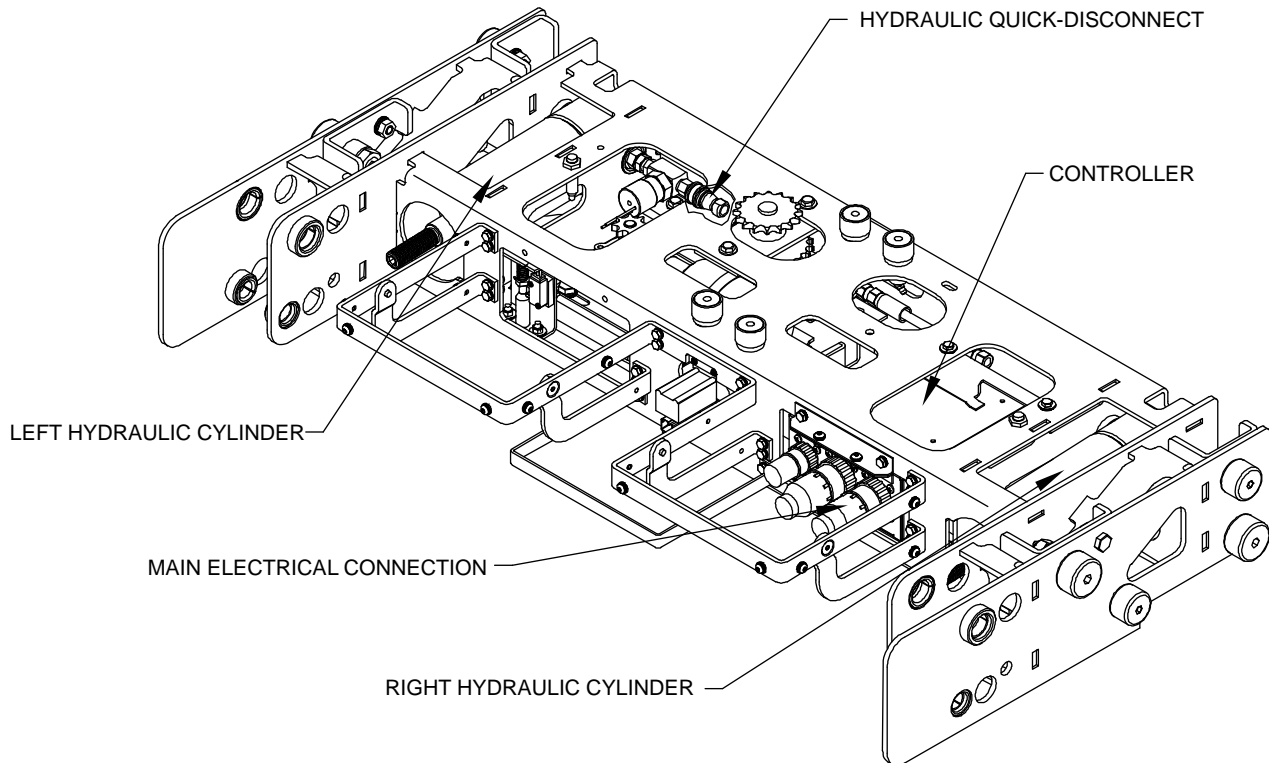

RSM0034400

FIGURE 4-15: CARRIAGE COMPONENTS

- i. Disconnect main electrical harness connector from electronic controller.
- j. Position a support stand in front of enclosure to place carriage on.

**WARNING!**

THE CARRIAGE ASSEMBLY IS HEAVY AND REQUIRES TWO PEOPLE TO REMOVE.

- k. Pull carriage out of enclosure, supporting each side, and place on support stand.

NOTE: Care is required while extracting carriage to avoid damage. Watch for possible points of interference.

Carriage Reinstallation

Perform reinstallation by reversing removal steps, with the following considerations. Pull hydraulic hose and electrical harness down through service access opening **before** inserting carriage into enclosure. Route hose and cable back into installed carriage in their original positions.

D. DEPLOYMENT SYSTEM SERVICE

Refer to **Figure 4-16**. Components in the deployment system move the travelling frame (carriage, lifting frame, and platform) out of the enclosure, or pull it back in. This section describes those components, including how they operate, how to remove and replace them, and how to perform adjustments.

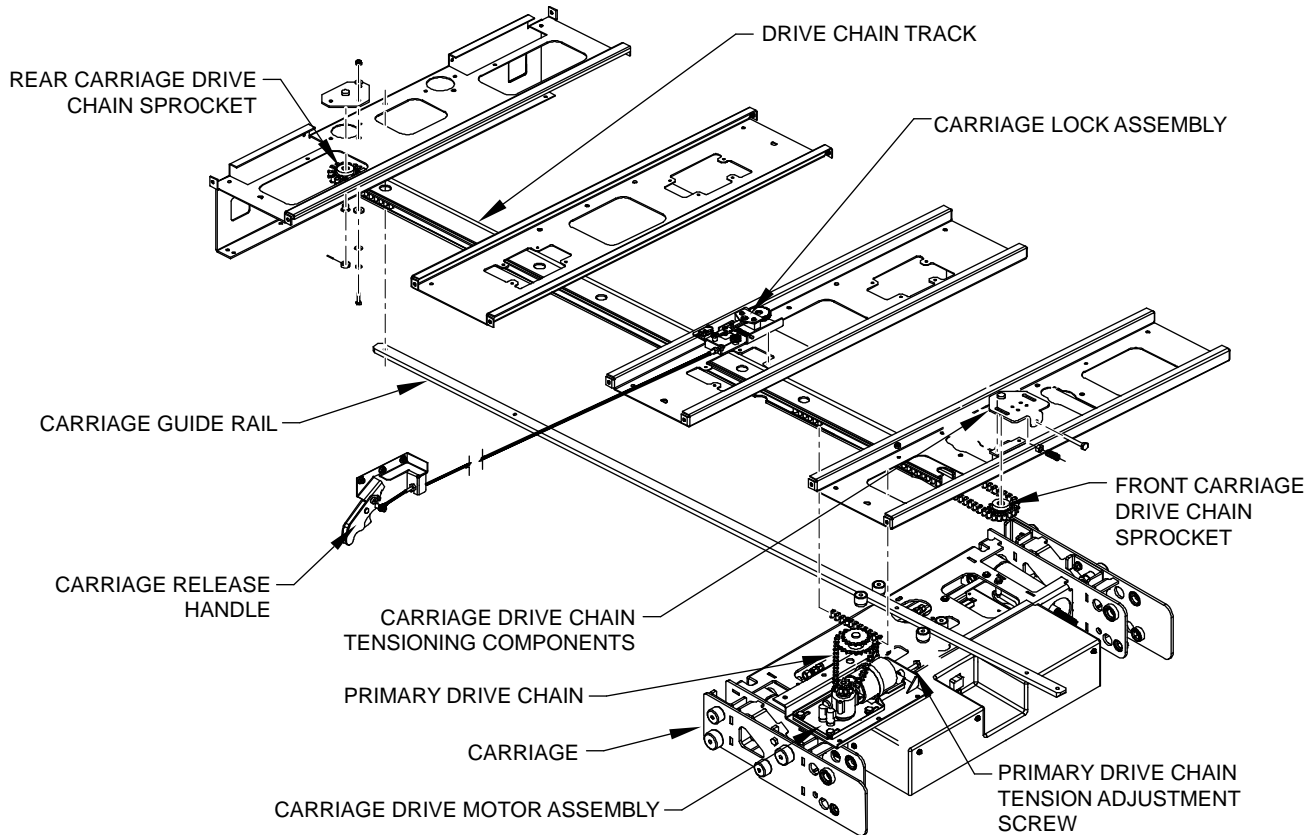

RSM0034500

FIGURE 4-16: DEPLOYMENT SYSTEM COMPONENTS

1. CARRIAGE DRIVE MOTOR ASSEMBLY

The carriage drive motor propels the deployment system, receiving electric power from the on-board electronic controller. The polarity of the applied voltage determines the direction of motor rotation, which also determines whether the platform is moved out of the enclosure or pulled into it. The motor drives a gearbox, which reduces motor speed and increases torque. The gearbox turns the primary drive chain.

a. Carriage Drive Motor Assembly Removal

- 1) Deploy platform using control pendant (DEPLOY).



WARNING!

- WEAR PROTECTIVE CLOTHING AND EYE PROTECTION AT ALL TIMES. BATTERIES CONTAIN ACID THAT CAN BURN. IF ACID COMES INTO CONTACT WITH SKIN, IMMEDIATELY FLUSH AFFECTED AREA WITH WATER AND WASH WITH SOAP.
- WORK IN A PROPERLY VENTILATED AREA. DO NOT SMOKE OR USE AN OPEN FLAME IN THE VICINITY OF BATTERY.
- DO NOT LAY ANYTHING METALLIC ON TOP OF BATTERY.

- 2) Disconnect positive battery cable at vehicle battery compartment.
- 3) Loosen jam nut on primary drive chain adjustment screw (located on mounting plate for carriage drive motor assembly) and turn screw CCW to slacken chain. Slip chain off of gearmotor sprocket and remove.
- 4) Label motor electrical leads for reinstallation, and then disconnect. Retain hardware.

- 5) Remove the six screws and nuts fastening gearmotor assembly to carriage. Slide gearmotor assembly forward, drop the rear-side down, and remove from carriage.
- 6) Remove the four screws fastening gearmotor assembly to its adjustable baseplate.
- 7) Remove motor retaining clamp and two nuts and washers that fasten gearbox to mounting plate.
- 8) Remove nuts and washers fastening motor to gearbox, and separate motor from gearbox; do not damage or lose rubber coupler.
- 9) Support chain sprocket and drive roll-pin out of sprocket. Pull sprocket off shaft.
- 10) Refer to next section for reinstallation.

b. **Carriage Drive Motor Assembly Installation**

- 1) Refer to **Figure 4-17**. Slide rubber coupler onto gearbox input shaft.

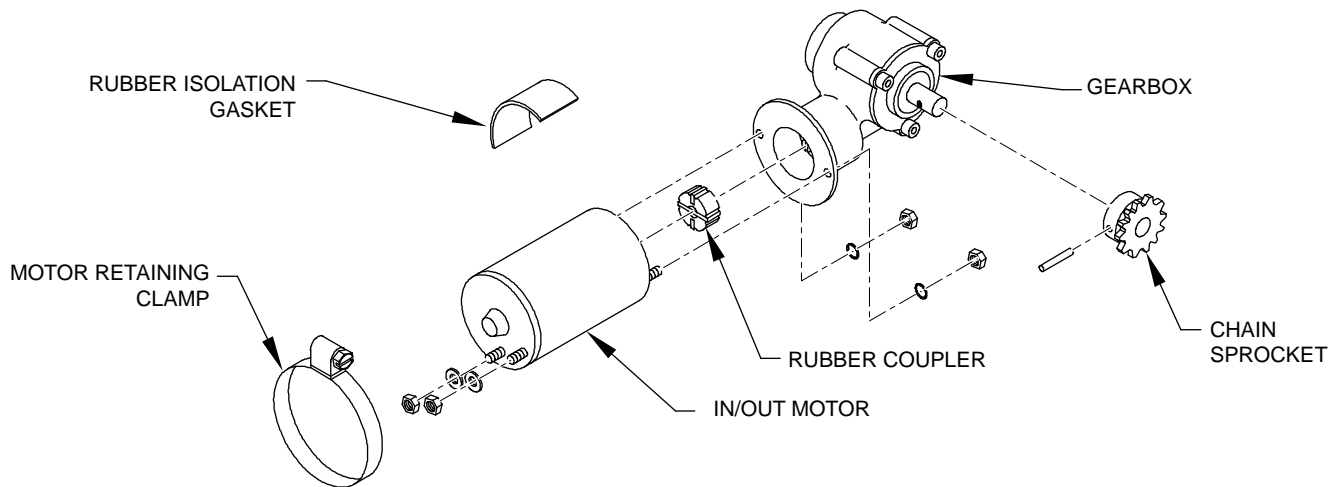

RSM0034600

FIGURE 4-17: CARRIAGE DRIVE MOTOR ASSEMBLY

- 2) Insert motor output shaft into coupler, and then align motor and gear box:
 - Hold motor with electrical connections pointed at you, and positioned at 5 o'clock.
 - Hold gearbox with its output housing up.
 - Align motor studs with holes in gearbox flange and assemble.
- 3) Install star-washers and nuts on motor studs, and tighten.
- 4) Place gearmotor assembly on mounting plate, with gearbox studs (and spacers) inserted in mounting plate. Install lock washers and nuts on gearbox studs; tighten.
- 5) Install motor retaining clamp; clamp fits over tab on gearmotor support bracket. Tighten clamp.
- 6) Refer to PRIMARY DRIVE CHAIN INSTALLATION section, and install primary drive chain. Refer to the PRIMARY DRIVE CHAIN ADJUSTMENT section and adjust the chain tension.
- 7) Reconnect the two electrical leads to motor.
- 8) Reconnect positive battery cable at vehicle battery compartment.

2. DRIVE CHAIN SERVICE

There are two chains in the deployment system. The primary drive chain couples the gearmotor to the carriage drive sprocket. The carriage drive sprocket is engaged with the carriage drive chain. The carriage drive chain is held stationary by the carriage lock assembly. Rotation of the carriage drive sprocket causes the carriage to be pulled along the stationary carriage drive chain.

a. Removal Of Drive Chains

⌘ PRIMARY DRIVE CHAIN

- 1) Deploy platform using control pendant (DEPLOY).

 WARNING!
<ul style="list-style-type: none"> • WEAR PROTECTIVE CLOTHING AND EYE PROTECTION AT ALL TIMES. BATTERIES CONTAIN ACID THAT CAN BURN. IF ACID COMES INTO CONTACT WITH SKIN, IMMEDIATELY FLUSH AFFECTED AREA WITH WATER AND WASH WITH SOAP. • WORK IN A PROPERLY VENTILATED AREA. DO NOT SMOKE OR USE AN OPEN FLAME IN THE VICINITY OF BATTERY. • DO NOT LAY ANYTHING METALLIC ON TOP OF BATTERY.

- 2) Disconnect positive battery cable at vehicle battery compartment.
- 3) Loosen jam nut on primary drive chain adjustment screw (located on mounting plate for carriage drive motor assembly) and turn screw CCW to slacken chain. Slip chain off of gearmotor sprocket and remove.

⌘ CARRIAGE DRIVE CHAIN

- 4) Deploy platform using control pendant (DEPLOY).
- 5) Unlock carriage drive chain to permit movement along its track. To do so, squeeze trigger on manual carriage release handle and pull handle upward; release trigger.
- 6) Refer back to **Figure 4-18**. Find the master link on carriage drive chain; hand-move carriage assembly forward or backward if the master link is not accessible.

 WARNING!
<ul style="list-style-type: none"> • WEAR PROTECTIVE CLOTHING AND EYE PROTECTION AT ALL TIMES. BATTERIES CONTAIN ACID THAT CAN BURN. IF ACID COMES INTO CONTACT WITH SKIN, IMMEDIATELY FLUSH AFFECTED AREA WITH WATER AND WASH WITH SOAP. • WORK IN A PROPERLY VENTILATED AREA. DO NOT SMOKE OR USE AN OPEN FLAME IN THE VICINITY OF BATTERY. • DO NOT LAY ANYTHING METALLIC ON TOP OF BATTERY.

- 7) Disconnect positive battery cable at vehicle battery compartment.
- 8) Loosen jam nut on carriage drive chain adjustment screw (screw is located on carriage drive chain tensioning assembly; jam nut is behind head of screw). Turn screw fully counter-clockwise to slacken chain.
- 9) Remove master-link from chain and remove chain.

NOTE: If there is not enough chain slack for removal of the master-link, move the carriage drive chain until the master-link is above one of the notches provided in chain track.

b. Installation Of Drive Chains

• PRIMARY DRIVE CHAIN

- 1) Deploy platform using control pendant (DEPLOY).

 **WARNING!**

- WEAR PROTECTIVE CLOTHING AND EYE PROTECTION AT ALL TIMES. BATTERIES CONTAIN ACID THAT CAN BURN. IF ACID COMES INTO CONTACT WITH SKIN, IMMEDIATELY FLUSH AFFECTED AREA WITH WATER AND WASH WITH SOAP.
- WORK IN A PROPERLY VENTILATED AREA. DO NOT SMOKE OR USE AN OPEN FLAME IN THE VICINITY OF BATTERY.
- DO NOT LAY ANYTHING METALLIC ON TOP OF BATTERY.

- 2) Disconnect positive battery cable at vehicle battery compartment.
 - 3) Loosen jam nut on primary drive chain adjustment screw (located on mounting plate for carriage drive motor assembly) and turn screw clockwise. Position chain around both sprockets of carriage drive motor assembly (small gearmotor sprocket and 22 tooth sprocket located just below carriage drive sprocket).
 - 4) Refer to Primary Drive Chain Adjustment section and adjust tension of primary drive chain.
- CARRIAGE DRIVE CHAIN
- 5) Deploy platform using control pendant (DEPLOY).

 **WARNING!**

- WEAR PROTECTIVE CLOTHING AND EYE PROTECTION AT ALL TIMES. BATTERIES CONTAIN ACID THAT CAN BURN. IF ACID COMES INTO CONTACT WITH SKIN, IMMEDIATELY FLUSH AFFECTED AREA WITH WATER AND WASH WITH SOAP.
- WORK IN A PROPERLY VENTILATED AREA. DO NOT SMOKE OR USE AN OPEN FLAME IN THE VICINITY OF BATTERY.
- DO NOT LAY ANYTHING METALLIC ON TOP OF BATTERY.

- 6) Disconnect positive battery cable at vehicle battery compartment.
- 7) Loosen jam nut on carriage drive chain adjustment screw (located on mounting plate for carriage drive chain tensioning assembly, behind head of adjustment screw) and turn screw fully clockwise.
- 8) Squeeze trigger on manual carriage release handle and pull handle upward; release trigger.
- 9) Install final drive chain around front and rear carriage drive chain sprockets, and route through the drive chain track. Bring ends together and install master link.
- 10) Refer to Carriage Drive Chain Adjustment section and adjust tension of carriage drive chain.

c. Drive Chain Tension Adjustment

Either drive chain can be adjusted first; the adjustment of one chain does not affect the other.

- CARRIAGE DRIVE SPROCKET

The carriage drive sprocket is constantly engaged with the carriage drive chain. The sprocket is mounted on an intermediate shaft that is driven by the primary drive chain. The shaft rotates on a bracket, which is fastened to the carriage with two screws. One of the screws passes through an adjustment slot in the bracket.

- 1) Loosen the four screws that fasten the drive motor assembly to its baseplate. Slide the drive motor assembly towards carriage drive chain.
- 2) Loosen the two screws that fasten the carriage drive sprocket bracket to the carriage.

NOTE: Loosen these screws just enough to allow movement of bracket.

- 3) Push bracket towards carriage drive chain with your hand. Push bracket just hard enough to make drive chain contact the bottom of its slot in the plastic track. Retighten screws.
- 4) Retighten the four screws that fasten the drive motor assembly to its baseplate, and then adjust primary drive chain (refer to following section).

- PRIMARY DRIVE CHAIN

NOTE: Adjust position of carriage drive sprocket **before** adjusting the primary drive chain. Refer to the Carriage Drive Sprocket section, above.

- 5) Deploy platform using control pendant (DEPLOY).

**WARNING!**

- WEAR PROTECTIVE CLOTHING AND EYE PROTECTION AT ALL TIMES. BATTERIES CONTAIN ACID THAT CAN BURN. IF ACID COMES INTO CONTACT WITH SKIN, IMMEDIATELY FLUSH AFFECTED AREA WITH WATER AND WASH WITH SOAP.
- WORK IN A PROPERLY VENTILATED AREA. DO NOT SMOKE OR USE AN OPEN FLAME IN THE VICINITY OF BATTERY.
- DO NOT LAY ANYTHING METALLIC ON TOP OF BATTERY.

- 6) Disconnect positive battery cable at vehicle battery compartment.
- 7) Refer to **Figure 4-18**. Locate the primary drive chain tension adjustment screw (located at the in-board end of carriage drive motor assembly), and fully loosen its jam nut. Loosen the four screws that fasten the gearmotor assembly to the baseplate.

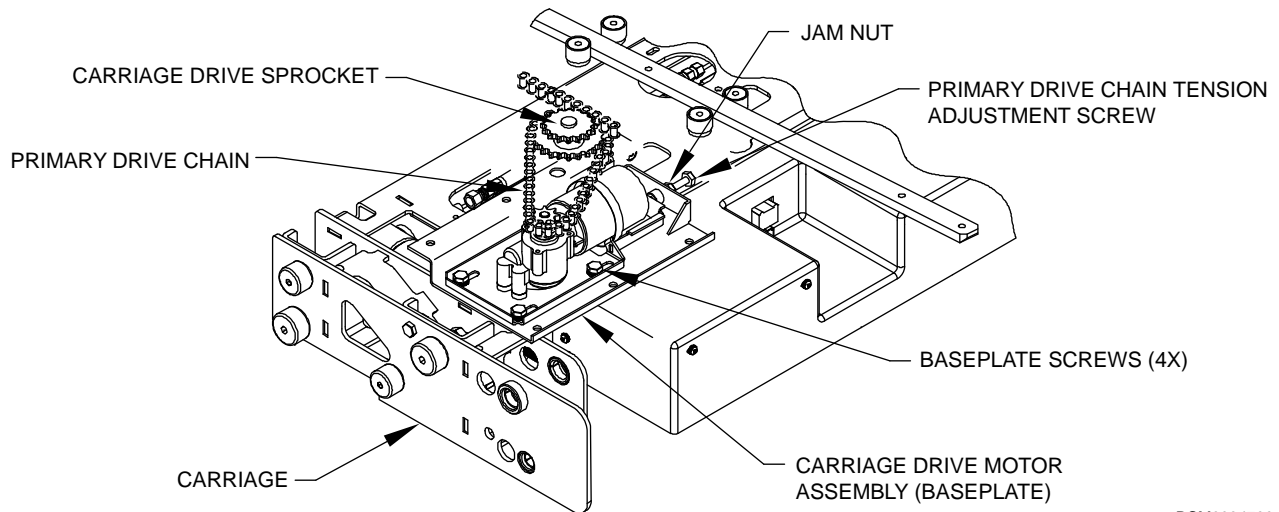

RSM0034700

FIGURE 4-18: DEPLOYMENT SYSTEM—PRIMARY DRIVE CHAIN

NOTE: Loosen the four screws just enough to allow movement of gearmotor assembly.

- 8) Rotate tension adjustment screw CW until all chain slack is removed; do not over-tighten chain or attempt to stretch chain. Tighten jam nut. Tighten the four baseplate screws.

NOTE: Rotating the tension adjustment screw CW increases chain tension; CCW decreases tension.

- 9) Reconnect positive battery cable at vehicle battery compartment.

- CARRIAGE DRIVE CHAIN
- 10) Deploy platform using control pendant (DEPLOY).

**WARNING!**

- WEAR PROTECTIVE CLOTHING AND EYE PROTECTION AT ALL TIMES. BATTERIES CONTAIN ACID THAT CAN BURN. IF ACID COMES INTO CONTACT WITH SKIN, IMMEDIATELY FLUSH AFFECTED AREA WITH WATER AND WASH WITH SOAP.
- WORK IN A PROPERLY VENTILATED AREA. DO NOT SMOKE OR USE AN OPEN FLAME IN THE VICINITY OF BATTERY.
- DO NOT LAY ANYTHING METALLIC ON TOP OF BATTERY.

- 11) Disconnect positive battery cable at vehicle battery compartment.
- 12) Refer to **Figure 4-19**. Locate the carriage drive chain tension adjustment screw at the front end of the carriage drive chain track. Loosen the jam nut located just behind the head of the adjustment screw. Loosen the two screws that fasten the baseplate to the enclosure.

NOTE: Loosen the two screws just enough to allow movement of the carriage drive chain tensioning assembly.

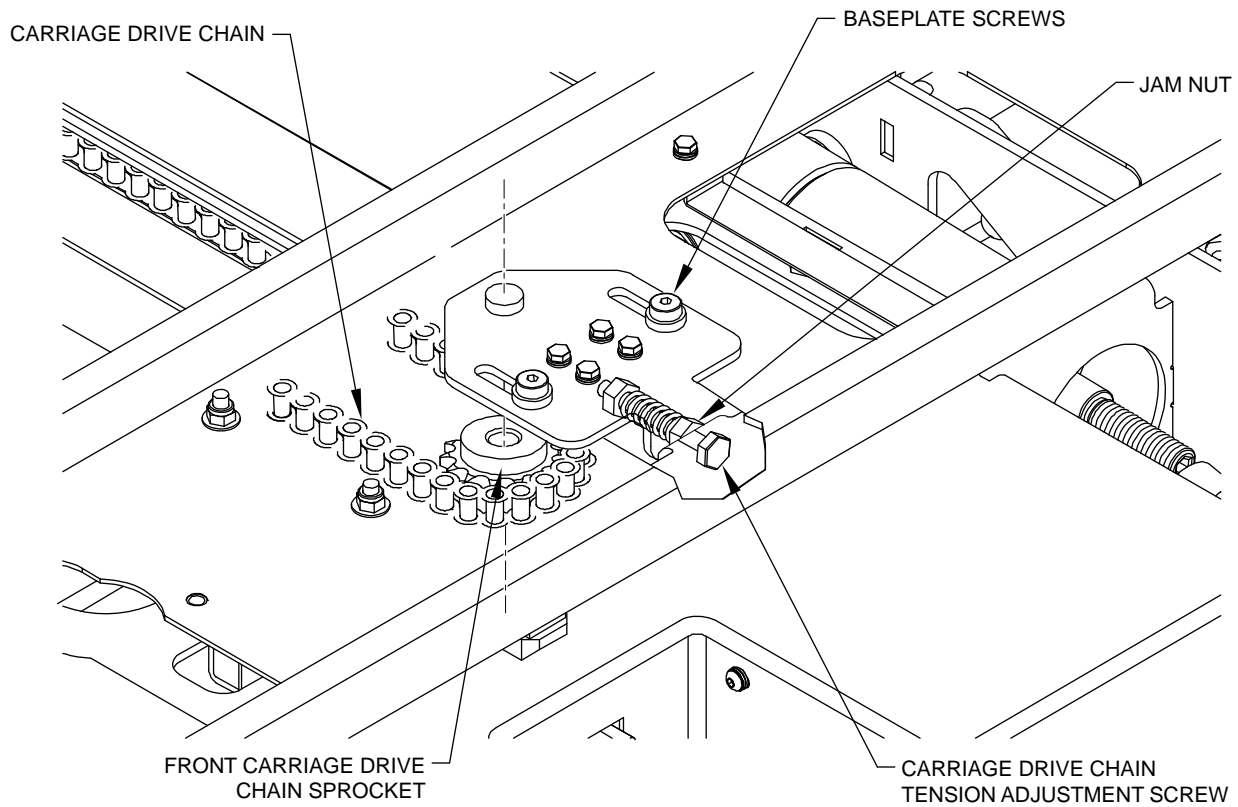

RSM0034800

FIGURE 4-19: DEPLOYMENT SYSTEM—CARRIAGE DRIVE CHAIN

- 13) Unlock the carriage drive chain by pulling the manual platform release handle upward (handle is located near hydraulic pump assembly).
- 14) Verify that entire carriage drive chain is free to move in its track.
- 15) Rotate tension adjustment screw CW until it spins freely. Tighten jam nut. Tighten two baseplate screws.

NOTE: Rotate the tension adjustment screw CW to increase chain tension, or CCW to decrease.

- 16) Release manual platform release handle and reconnect positive battery cable at vehicle battery compartment.

3. CARRIAGE LOCK ASSEMBLY

Refer to **Figure 4-20**. The carriage drive chain is normally held stationary by the carriage drive chain lock assembly. The lock assembly is fastened to the enclosure. Moving the carriage (part of the travelling frame) by hand is difficult when the chain is held stationary because you must overcome the resistance of the deployment system. The carriage can be manually disengaged from the enclosure with the manual platform release handle (located near hydraulic pump assembly).

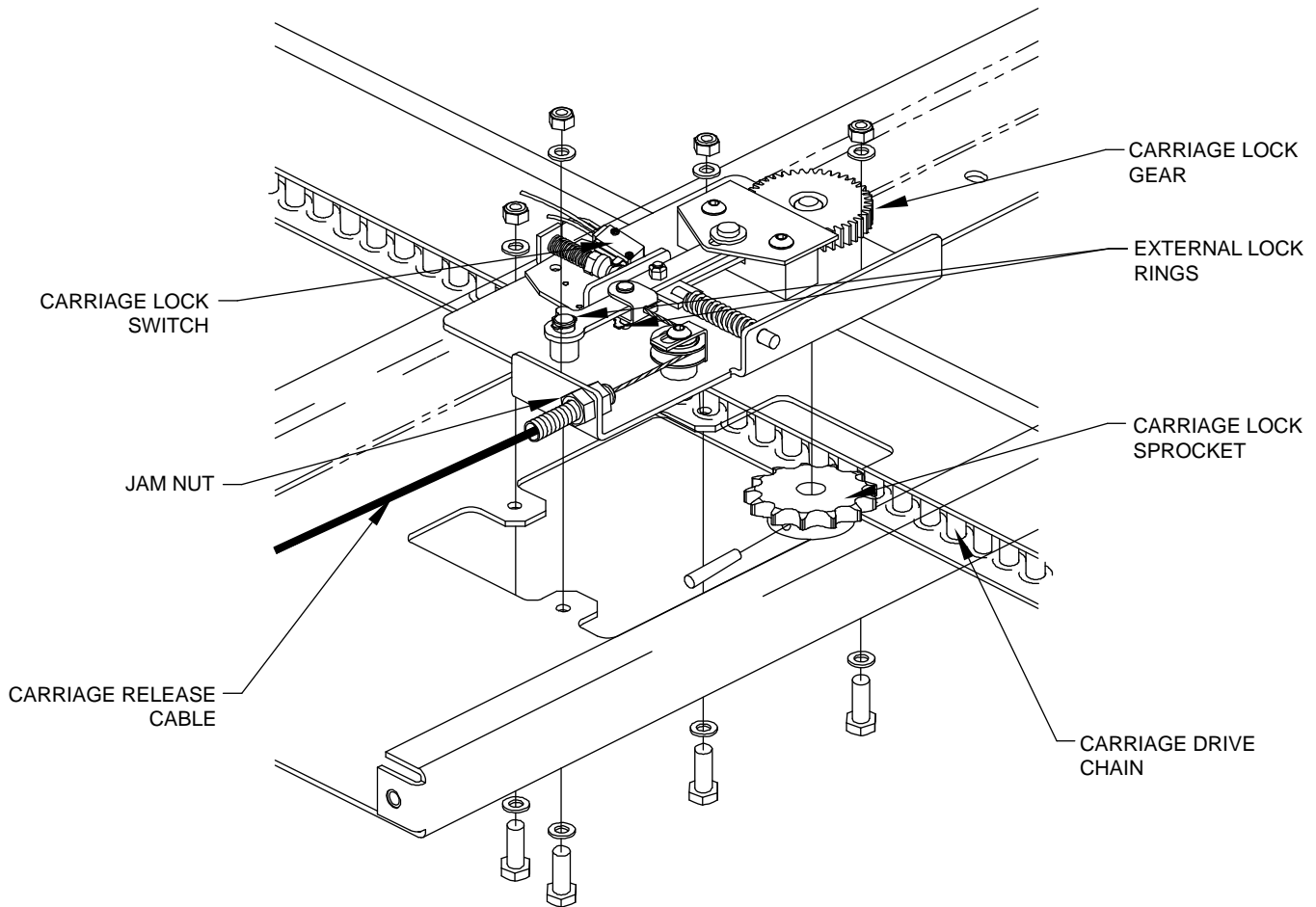

RSM0034900

FIGURE 4-20: CARRIAGE DRIVE CHAIN LOCK ASSEMBLY

Pulling the release handle upward unlocks the carriage drive chain, allowing it to move freely along the chain track. The travelling frame is now easily moved by hand because it is separated from the deployment system.

Refer to the Maintenance Checklist in Chapter III. The carriage drive chain lock assembly is infrequently used, and normally requires little maintenance. It should be inspected periodically for wear and damage. It should be cleaned and lubricated if it does not operate smoothly and properly when the remote carriage release handle is used.

4. CARRIAGE RELEASE CABLE

This cable connects the release handle (located near hydraulic pump) to the carriage drive chain lock assembly (located on top side of enclosure). The cable is in two sections, with the junction located on the harness bracket (on outside of enclosure). Cable length adjustment is straightforward, and can be done at the harness bracket or at the carriage drive chain lock assembly. Adjust length by loosening and unthreading one of the jam nuts, then move the threaded portion of the cable housing in or out of its mounting hole. Retighten jam nut.

Under normal conditions, the lock sprocket is engaged with the carriage drive chain. If a residual tension is present in the release cable, the lock sprocket may be encouraged to disengage from the drive chain. Provide a slight amount of slack in the release cable to make certain the sprocket remains fully engaged with the chain.

Verify that the lock sprocket completely disengages from the carriage drive chain when the remote release handle is pulled.

5. CARRIAGE LOCK SWITCH

Figure 4-20 shows the carriage drive chain lock assembly in the locked state. In this state, the switch is held activated by a tab on the locking linkage, and there will be a closed circuit across its red and blue leads. When the manual release handle is pulled, the cable pulls the linkage away from the switch, and the switch returns to its normal state (unactivated).

If the switch is an open circuit when the chain is locked in place, loosen the two switch retaining screws and slide the switch towards the linkage tab. Retighten the screws. Verify that switch opens when the remote release handle is pulled.

E. HYDRAULIC SYSTEM

Refer to **Figure 4-21**. Major hydraulic system components are an electric motor, a gear-pump, a fluid reservoir, two hydraulic cylinders (rams), control valves, and a manual back-up pump.

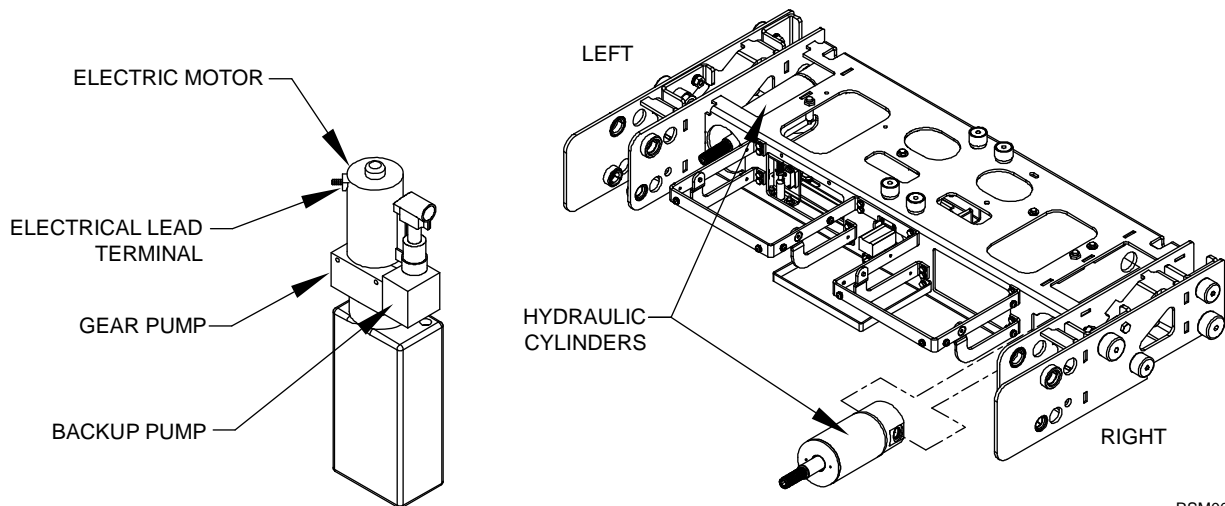

FIGURE 4-21: HYDRAULIC SYSTEM COMPONENTS

1. SYSTEM FLUID RENEWAL

- a. Deploy platform using control pendant (DEPLOY).
- b. Slowly open manual release valve (located on back-up pump) to release hydraulic pressure, and allow platform to lower to ground.
- c. Loosen clamp fastening fluid reservoir to pump.
- d. Carefully pull reservoir from bottom of pump and empty into an appropriate waste container.
- e. Reinstall reservoir on pump, and tighten clamp.
- f. Remove reservoir fill plug. Fill reservoir with Texaco 01554 Aircraft Hydraulic Oil, or equivalent U.S. mil spec H5606G fluid.
- g. Close manual release valve.
- h. Use control pendant to raise platform to floor level, and then lower it to ground level. Repeat cycle three times.
- i. Slowly open manual release valve to release hydraulic pressure.
- j. Repeat steps **c.** through **h.** and then proceed to step **k.**
- k. Close manual release valve.
- l. Refer to HYDRAULIC BLEEDING section in Chapter II and bleed system.

2. ELECTRIC PUMP MOTOR

a. Pump Motor Removal

- 1) Deploy platform using control pendant (DEPLOY), and then support.

 WARNING!
<ul style="list-style-type: none"> • WEAR PROTECTIVE CLOTHING AND EYE PROTECTION AT ALL TIMES. BATTERIES CONTAIN ACID THAT CAN BURN. IF ACID COMES INTO CONTACT WITH SKIN, IMMEDIATELY FLUSH AFFECTED AREA WITH WATER AND WASH WITH SOAP. • WORK IN A PROPERLY VENTILATED AREA. DO NOT SMOKE OR USE AN OPEN FLAME IN THE VICINITY OF BATTERY. • DO NOT LAY ANYTHING METALLIC ON TOP OF BATTERY.

- 2) Disconnect positive battery cable at vehicle battery compartment.

- 3) Refer to **Figure 4-22**. Disconnect heavy electrical lead from top of pump motor (electric terminal in figure is rotated 90° CCW, for clarity).
- 4) Remove motor body from pump body by unthreading the two long screws that pass through motor body; do not remove screws.

NOTE: Hold end caps in-place when removing motor body.

b. Electric Pump Motor Installation

This procedure assumes that pump motor has been removed.

- 1) Inspect shaft seal in pump body for signs of leakage; replace, if necessary.
- 2) Refer to **Figure 4-22**. Locate motor body assembly on pump body (hold motor assembly together).
- 3) Align screw holes in end caps, motor body, and pump body. Insert two long retaining screws and lightly tighten.
- 4) Connect a 24 VDC power source to motor assembly. Connect positive lead to motor terminal and negative lead to pump body.
- 5) Carefully tighten retaining screws as motor spins (hold upper end cap). Do not over tighten screws.
- 6) Raise platform to floor level. Repeat steps 4) and 5) if pump motor is noisy.
- 7) Check all hydraulic connections for leaks, and correct as required.
- 8) If seal in pump body was replaced, refer to HYDRAULIC BLEEDING section in Chapter II and bleed system.

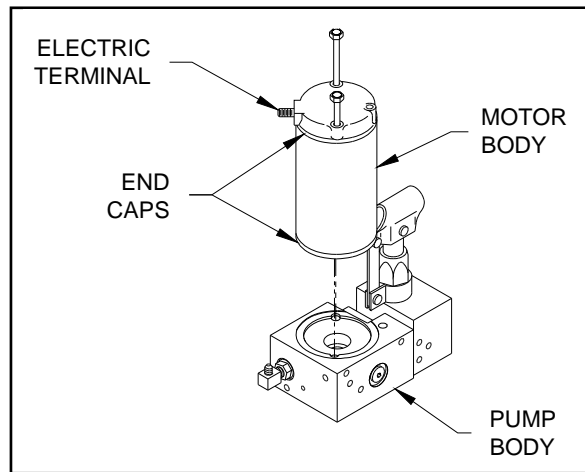
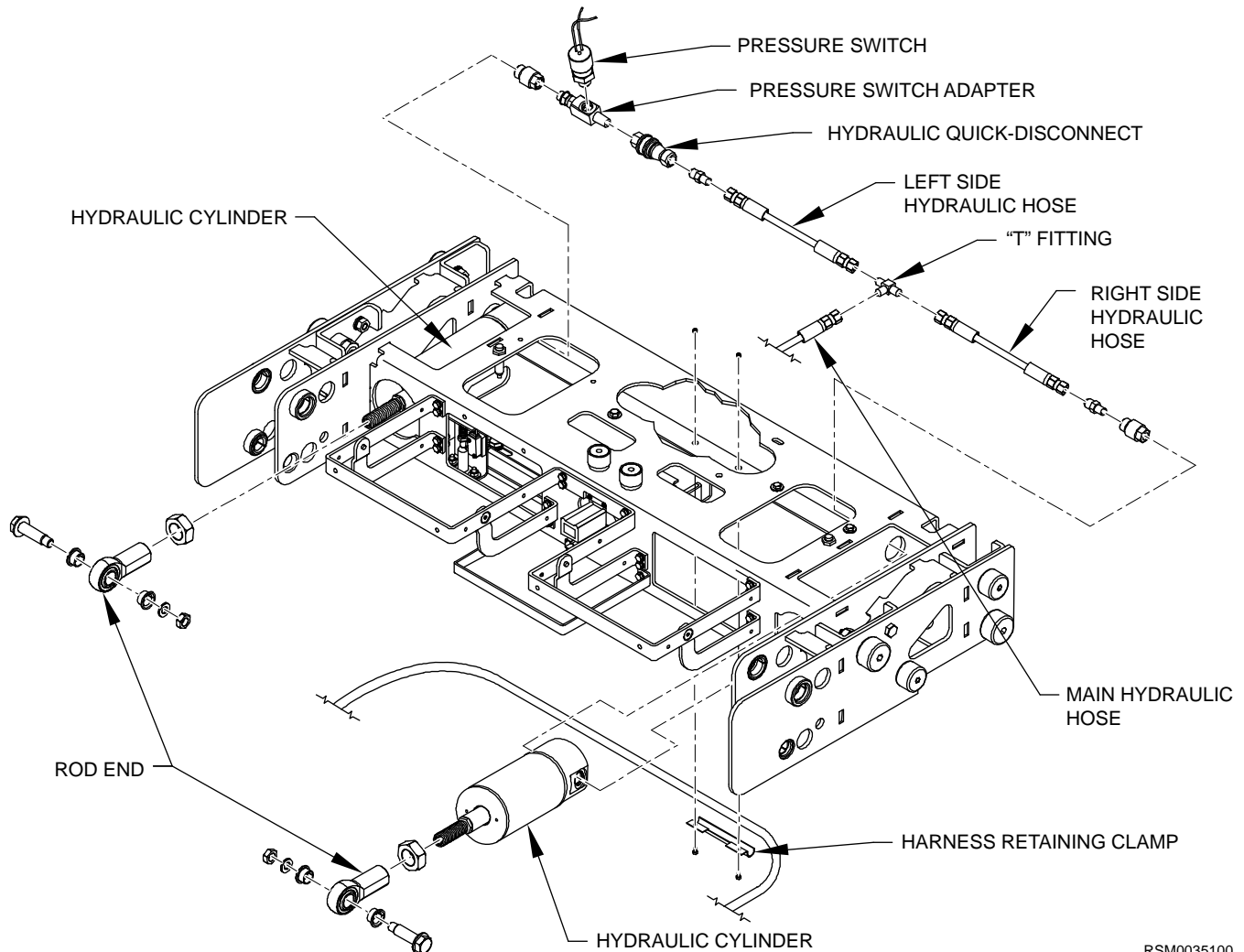

FIGURE 4-22: PUMP MOTOR ORIENTATION

3. HYDRAULIC CYLINDERS

Refer to **Figure 4-23**. The force required to lift the platform is provided by two hydraulic cylinders. The cylinders are located near the left and right sides of the carriage. One of the cylinders contains a linear potentiometer, and this cylinder is typically installed on the left side. The following procedures describe the removal and installation of one cylinder; the procedures are the same for the second cylinder.



RSM0035100

FIGURE 4-23: HYDRAULIC CYLINDERS AND RELATED COMPONENTS

a. Removing a Hydraulic Cylinder

The following procedure describes the removal and installation of one cylinder; the procedure is the same for the other cylinder.

- 1) Deploy platform using control pendant (DEPLOY).
- 2) Raise and support platform at a comfortable working height.

⚠ WARNING!

- WEAR PROTECTIVE CLOTHING AND EYE PROTECTION AT ALL TIMES. BATTERIES CONTAIN ACID THAT CAN BURN. IF ACID COMES INTO CONTACT WITH SKIN, IMMEDIATELY FLUSH AFFECTED AREA WITH WATER AND WASH WITH SOAP.
- WORK IN A PROPERLY VENTILATED AREA. DO NOT SMOKE OR USE AN OPEN FLAME IN THE VICINITY OF BATTERY.
- DO NOT LAY ANYTHING METALLIC ON TOP OF BATTERY.

- 3) Disconnect positive battery cable at vehicle battery compartment.
- 4) Open manual release valve on hydraulic pump and leave open.
- 5) Remove cover at front of carriage.
- 6) Loosen jam nut then extract hydraulic cylinder pivot pin from the common bore that passes through the lifting frame arm and each 3/4 in. (19mm) rod end. Examine the pivot bushings installed in the lifting frame and for excessive wear or damage.
- 7) Push cylinder shaft (with rod end) towards cylinder body until rod end is clear of lifting frame. Don't remove rod end at this time.

- 8) Disconnect electrical harness from cylinder, if the cylinder is equipped with a linear potentiometer. Protect exposed connectors on harness and cylinder.

NOTE: The following step will spill hydraulic fluid; have dry rags on hand.

- 9) Remove hose retaining clamp at rear of carriage. Disconnect quick-disconnect fitting from pressure switch adapter.
- 10) Disconnect hydraulic hose from pivot fitting at right side cylinder; loosen and remove pressure switch from adapter at left side cylinder.
- 11) Unthread pivot fitting from inboard side of cylinder.
- 12) Support cylinder, and then unthread pivot plug from outboard side of cylinder; this will release cylinder from carriage.
- 13) Carefully remove cylinder and rod end assembly through front or top of carriage.
- 14) Examine the pivot bushings installed in the back of carriage for excessive wear or damage. Loosen jam nut on cylinder shaft, and remove rod end.
- 15) Repeat process for second cylinder, if necessary.

NOTE: Refer to **Figure 4-24**. To make reassembly and adjustment of the rod end easier, measure and record the length of the exposed threaded portion of the cylinder shaft. This length can be used as an initial setting when the rod end is reinstalled on the shaft.

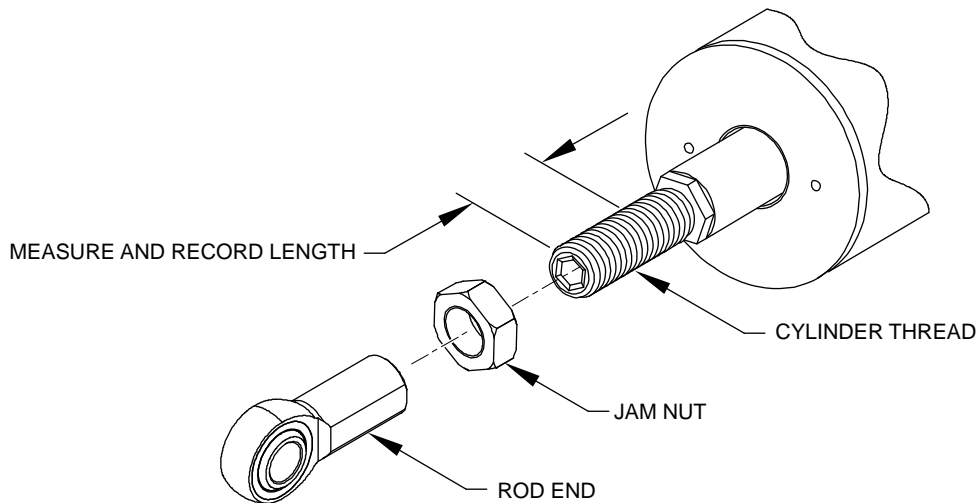

RSM0035300

FIGURE 4-24: ROD END POSITION

b. Hydraulic Cylinder Installation

This procedure assumes the hydraulic cylinder has been removed.



CAUTION!

The cylinder shaft threads must engage with at least .75 in. (1905mm) of the rod end threads.

- 1) Refer back to **Figures 4-24** and **4-25**. Assemble jam nut and rod end onto hydraulic cylinder shaft. Position rod end on shaft with measurement taken during removal. Install two flanged cylinder pivot bushings into carriage frame (with flanges facing cylinder).
- 2) Insert rear of hydraulic cylinder through D-shaped opening in front of carriage, or drop assembly through rectangular opening on top of carriage.
- 3) Align cylinder ports with flanged bushings. Install pivot plug through cylinder pivot bushing (installed in carriage frame) and into outboard side of cylinder.
- 4) Install pivot fitting through cylinder pivot bushing and into inboard side of cylinder.
- 5) Reconnect hydraulic hose to pivot fitting at right side cylinder; reinstall pressure switch into adapter at left side cylinder.
- 6) Reconnect quick-disconnect fitting to pressure switch adapter. Reinstall hose retaining clamp.
- 7) Reconnect electrical harness to cylinder equipped with linear potentiometer.

- 8) Verify that hydraulic pump manual release valve is closed. Use the manual backup pump to extend rod end until its bushings align with the bushings in the lifting frame arm.
- 9) Insert rod end pivot pin into common bore passing through lifting frame bushings and rod end bushings. Center pivot pin in rod end, and replace setscrew. Apply a thread locker (such as loc-TITE® blue or omniFIT® blue) when reinstalling setscrew.
- 10) Repeat process for second cylinder, if necessary.
- 11) Replace cover at front of carriage.
- 12) Refer to HYDRAULIC BLEEDING section in Chapter II and bleed system.
- 13) Raise platform to maximum height possible using manual back-up pump. The platform must be 1 in.–1 ½ in. (25mm-38mm) above the floor at maximum height. Note whether platform needs to be raised or lowered. Refer to the PLATFORM VERTICAL TRAVEL LIMIT ADJUSTMENT section in Chapter II if adjustment is necessary.
- 14) Refer to PLATFORM HEIGHT ADJUSTMENT section in Chapter II, and program stow and floor height.
- 15) Refer to the ANTI-STOW PRESSURE SWITCH ADJUSTMENT section in Chapter II after installing components in the hydraulic system. The pressure switch should detect the presence of a 75 lb. load, or greater, on the deployed platform.

4. ANTI-STOW PRESSURE SWITCH ADJUSTMENT

An adjustable, pressure sensing, electrical switch is installed in the hydraulic line connected to the hydraulic cylinders. The pressure switch can detect the presence of a 75 lb. load, or greater, on the platform. The switch will signal the controller when a load is present, and prevent stowage of the platform. This provides a margin of safety for lift users. Refer to the Anti-stow Pressure Switch Adjustment section in Chapter II after doing major repair or replacement of components in the hydraulic system.

5. HYDRAULIC HOSE AND MAIN ELECTRICAL HARNESS

A single flexible conduit, containing both a hydraulic hose and an electrical harness, is routed inside the enclosure. It is routed between the carriage and the enclosure harness bracket (located on the outside of the enclosure). This hydraulic hose is one section of a line connecting the hydraulic pump (located near hydraulic pump assembly) to the hydraulic platform lifting cylinders. The electrical harness provides power to the lift, and carries pendant and hydraulic pump motor signals to the carriage-mounted electronic controller.

c. Hydraulic Hose and Main Electrical Harness Removal

- 1) Refer to CARRIAGE REMOVAL section and remove platform, lifting frame, and carriage.
- 2) Refer to **Figure 4-25**. Remove hose retaining clamp from bottom of carriage. Remove two harness clamps (behind harness bracket, inside enclosure).

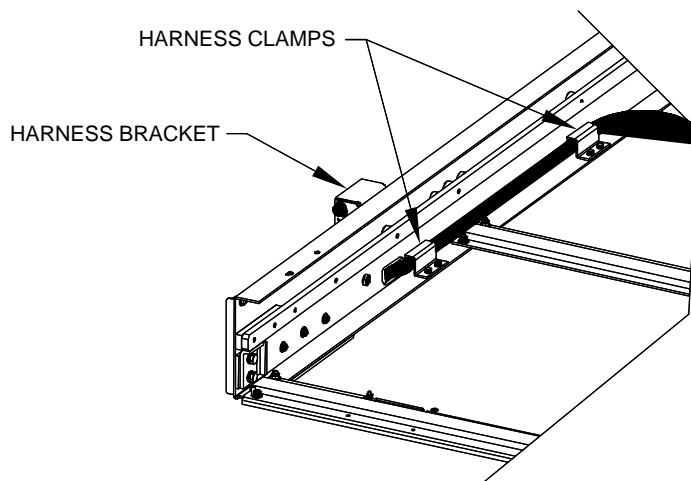

RSM0035200

FIGURE 4-25: HARNESS CLAMPS
(located in enclosure interior, behind enclosure harness bracket)

- 3) Disconnect main electrical harness from electronic controller (mounted in carriage). Also, disconnect main electrical harness from pendant harness connector and pump harness connector (at harness bracket).

NOTE: The following step will spill hydraulic fluid; have dry rags on hand.

- 4) Disconnect hydraulic hose from "T" fitting at rear of carriage, and from bulkhead fitting on harness bracket.
- 5) Note routing of conduit and how it is secured.
- 6) Remove main electrical harness and hydraulic hose from enclosure (cut nylon tie wraps, where necessary).

d. **Hydraulic Hose and Main Electrical Harness Installation**

This procedure assumes the conduit containing the main electrical harness and hydraulic hose has been removed.

- 1) Remove platform, lifting frame, and carriage, if present. Refer to CARRIAGE REMOVAL section.
- 2) Route main electrical harness and hydraulic hose conduit from harness bracket to carriage. Note that conduit is guided into rear of carriage by a curved barrier on the bottom of carriage.
- 3) Connect hydraulic hose to fitting on harness bracket. Connect main electrical harness to pendant connector and pump harness connector (also on harness bracket).
- 4) Route conduit to carriage.
- 5) Connect hydraulic hose to "T" fitting at rear of carriage. Connect electrical harness to electronic controller (mounted in carriage).
- 6) Position conduit so that it moves freely as carriage moves in and out of enclosure; it must not interfere with carriage movement. The conduit must lie flat against the bottom enclosure covers, and must not twist or loop as carriage moves. Secure conduit with nylon tie wraps, where necessary.
- 7) Refer back to **Figures 4-23** and **4-25**. Install hose retainer clamp on bottom of carriage. Install two hose clamps (behind pull box, inside enclosure).
- 8) Refer to end of Carriage Removal section for instructions to reinstall carriage.
- 9) Refer to HYDRAULIC BLEEDING section in Chapter II and bleed system.

6. **STOW LOCK ASSEMBLY**

The stow lock secures the lift when stowed. Stow lock striker weldment is attached to the right hand side platform and the stow lock assembly is attached to the enclosure.

a. **Stow Lock Striker Weldment Removal**

- 1) Refer to **Figure 4-26**. Deploy platform using control pendant (DEPLOY).
- 2) Remove two bolts and washers then detach Stow Lock Striker from PRS cover on right hand side of platform.

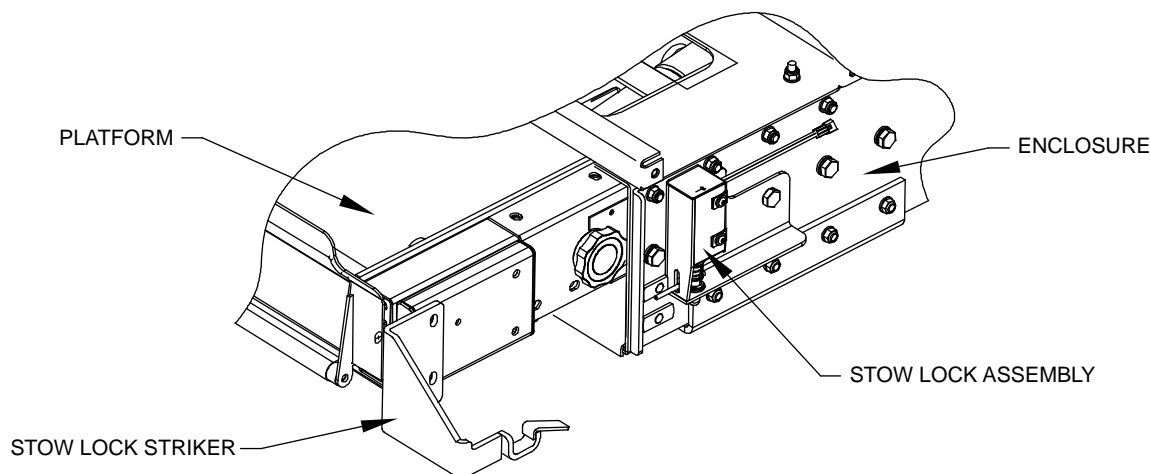

RSM0035400

FIGURE 4-26: STOW LOCK ASSEMBLY

- 3) Retain hardware for reinstallation.

b. **Stow Lock Assembly Removal**

- 1) Refer to **Figure 4-27**. Deploy platform using control pendant (DEPLOY).
- 2) Detach cable connection of Stow Lock Solenoid Assembly.
- 3) Remove bolt and washer then detach Stow Lock from right hand side of enclosure.
- 4) Retain hardware for reinstallation.

F. ELECTRICAL CONTROLS

1. GENERAL PROCEDURE FOR REPLACEMENT OF LIMIT SWITCHES

There are several limit switches installed in the platform and carriage. The switches are hard-wired to a harness at the factory, but can be replaced in the field. Replacement switches are supplied with three wire-leads (pigtails). Use this procedure to wire a replacement switch into a harness.

WARNING!

- WEAR PROTECTIVE CLOTHING AND EYE PROTECTION AT ALL TIMES. BATTERIES CONTAIN ACID THAT CAN BURN. IF ACID COMES INTO CONTACT WITH SKIN, IMMEDIATELY FLUSH AFFECTED AREA WITH WATER AND WASH WITH SOAP.
- WORK IN A PROPERLY VENTILATED AREA. DO NOT SMOKE OR USE AN OPEN FLAME IN THE VICINITY OF BATTERY.
- DO NOT LAY ANYTHING METALLIC ON TOP OF BATTERY.

- a. Disconnect positive battery cable at vehicle battery compartment.
- b. Note length and colors of wire leads on switch to be replaced (a red lead and a blue lead, a red lead and a yellow lead, etc).
- c. Cut wire leads on replacement switch to appropriate length; cut leads extra-long if unsure of exact length. Strip 1/4 in. (6mm) of insulation off ends of wires.
- d. Place a 1 in. (25mm) length of 1/4 in. (6mm) shrinkable tubing around each switch wire if you are going to solder the new connections. Slide tubing away from end of wire.
- e. Connect each harness lead to appropriate lead on replacement switch. The leads can be joined with crimp-on butt connectors, or soldered.

NOTE: Contact Ricon Product Support if replacement switch leads are a different color than the switch being replaced

- f. Verify integrity of each connection by attempting to pull it apart.
- g. Slide the shrinkable tubing over soldered connections, and shrink with a heat gun.
- h. Cut unused switch lead close to switch body.
- i. Remove original switch from its bracket and mount replacement switch in its place.
- j. Refer to appropriate Switch Adjustment section in this chapter and set switch position.
- k. Reconnect positive battery cable at vehicle battery compartment.

2. REPLACEMENT OF ELECTRONIC CONTROLLER

The electronic circuitry inside the controller box receives command inputs from the pendant, and signal inputs from sensors in the carriage and lifting frame. It also monitors and controls all lift functions. There are no parts in the controller that can be replaced in the field. The entire controller must be replaced, if at fault. Verify that replacement controller is appropriate for the application being worked on.

CAUTION!

The electronic controllers used in the various Ricon Mirage models are visually similar and physically interchangeable. However, their programming and internal circuitry are different, and they must not be installed in a lift they were not designed for.

- a. Fully deploy lift.
- b. The controller is removed from the front of the carriage (through access window in carriage).
- c. Disconnect three harness connectors from controller.
- d. Remove two Phillips screws fastening connector-end of controller to its mounting bracket.
- e. Slide controller off of rear bracket (fastened to rear of carriage), and remove controller from carriage.
- f. Position replacement controller inside carriage. Slide loop (at top, rear of controller housing) onto mounting bracket tab.
- g. Reinstall two Phillips screws fastening connector-end of controller.
- h. Reconnect the three harness connectors to controller, and tighten securely.

NOTE: Each connector is uniquely keyed, and cannot be interchanged. However, do not attempt to force a connector plug onto a receptacle if you encounter resistance.

- i. Reconnect positive battery cable at vehicle battery compartment.

3. HYDRAULIC HOSE AND MAIN ELECTRICAL HARNESS

A single flexible conduit, containing both a hydraulic hose and an electrical harness, is routed inside the enclosure. It is routed between the carriage and the enclosure harness bracket (located on the outside of the enclosure). This hose is one section of a hydraulic line connecting the hydraulic pump (located near hydraulic pump assembly) to the hydraulic platform lifting cylinders. The electrical harness provides power to the lift, and carries pendant and hydraulic pump motor signals to the carriage-mounted electronic controller. Refer to the Hydraulic Hose and Main Electrical Harness paragraph in the Hydraulic Power System section for removal and installation instructions.

V. F10X-SERIES SPARE PARTS

This chapter contains parts illustrations and parts lists for the RICON F10X-Series DOT Public Use Motor Coach Wheelchair and Standee Lift. Each exploded view of a major lift assembly shows smaller assemblies, components, and kits referenced with numbers. The exploded view is followed by an associated parts list that contains the reference numbers, part descriptions, quantities required for the major assembly shown, and Ricon part numbers.

To order a part: Locate the part or assembly on an exploded view, and note its reference number. Find this number on the associated parts list (following page), and order the Ricon part number in the far right column.

NOTE:

- Most items that are described as “kits” contain a single part (plus hardware). Therefore, you may need to order more than one kit if the part is used more than once on the assembly shown.
- Small, inexpensive hardware items are supplied in a minimum quantity of ten, and are packaged in a bag. A single bag may provide more parts than you need, or you may need multiple bags when working on a large assembly. The QTY/ASSY column indicates how many individual parts are used on the assembly shown; you will need to determine the number of bags required for your task.

NOTE: The reference numbers for some parts have more than one part number listed. This occurs when variations of a part are used on different lift models. These parts are followed by a model designation (F10XF-0001, F10XF-0002, etc)..

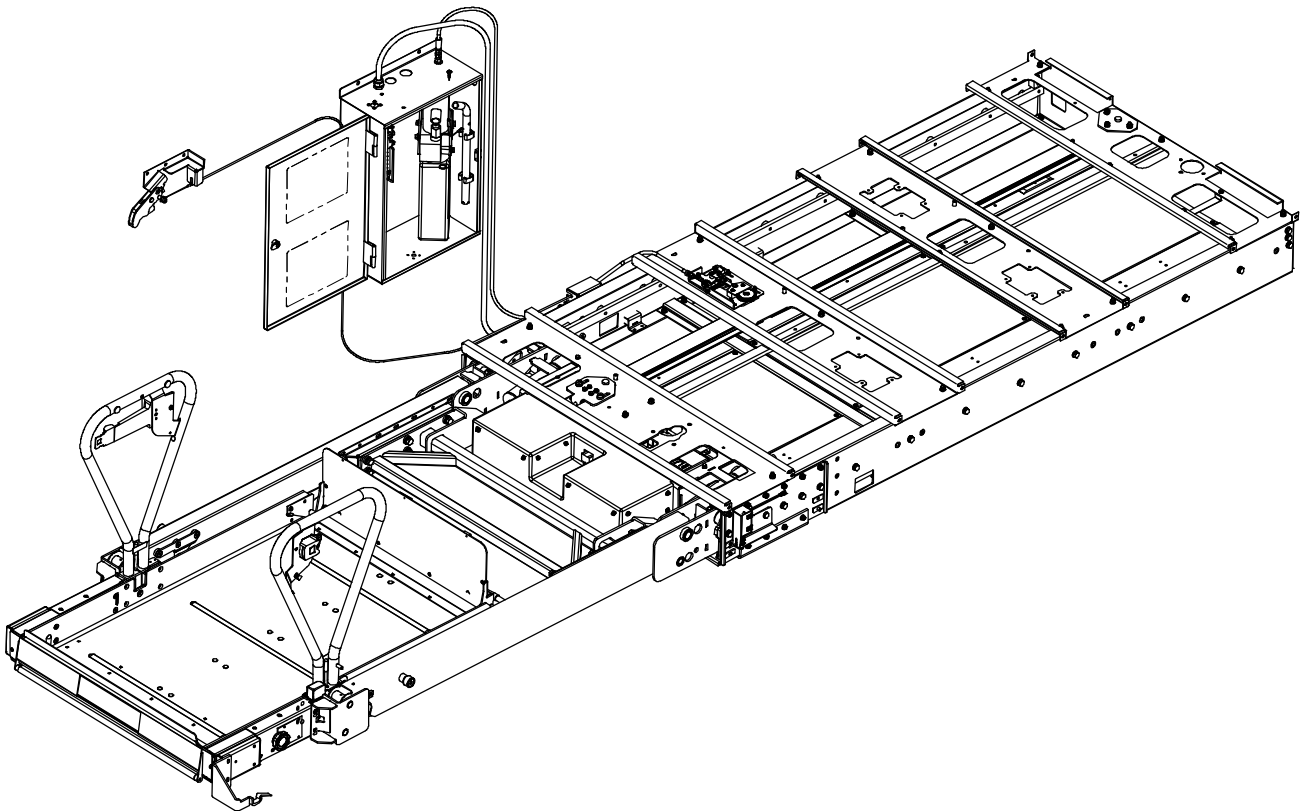

LIFT MODEL AND KIT NUMBERS	
PRODUCT NUMBER	F10XF-0001 (first model in number sequence)
DOCUMENTATION KIT NUMBER	44266
SPARE DECAL KIT NUMBER	46500
SPARE PARTS BOM	45863

PARTS DIAGRAM.....		PAGE
FIGURE 5-1	F10X DECAL LOCATIONS AND PART NUMBERS	5-4
FIGURE 5-2	F10X PUMP ASSEMBLY	5-6
FIGURE 5-3	F10X LIFTING FRAME ASSEMBLY	5-10
FIGURE 5-4	F10X ENCLOSURE ASSEMBLY	5-12
FIGURE 5-5	F10X PLATFORM ASSEMBLY	5-14
FIGURE 5-6	F10X CARRIAGE ASSEMBLY	5-18
FIGURE 5-7	F10X POWER ROLLSTOP ASSEMBLY, RIGHT SIDE	5-22
FIGURE 5-8	F10X ROLLSTOP LATCH, LEFT SIDE	5-24
FIGURE 5-9	F10X BRIDGEPLATE ASSEMBLY.....	5-26
FIGURE 5-10	F10X CARRIAGE RELEASE HANDLE ASSEMBLY AND PENDANT ASSEMBLY	5-28
FIGURE 5-11	F10X STOW LOCK ASSEMBLY	5-30
APPENDIX 1	LIFT SPECIFICATIONS	5-33

This page intentionally left blank.

DECALS AFFIXED TO OUTSIDE OF PUMP BOX COVER

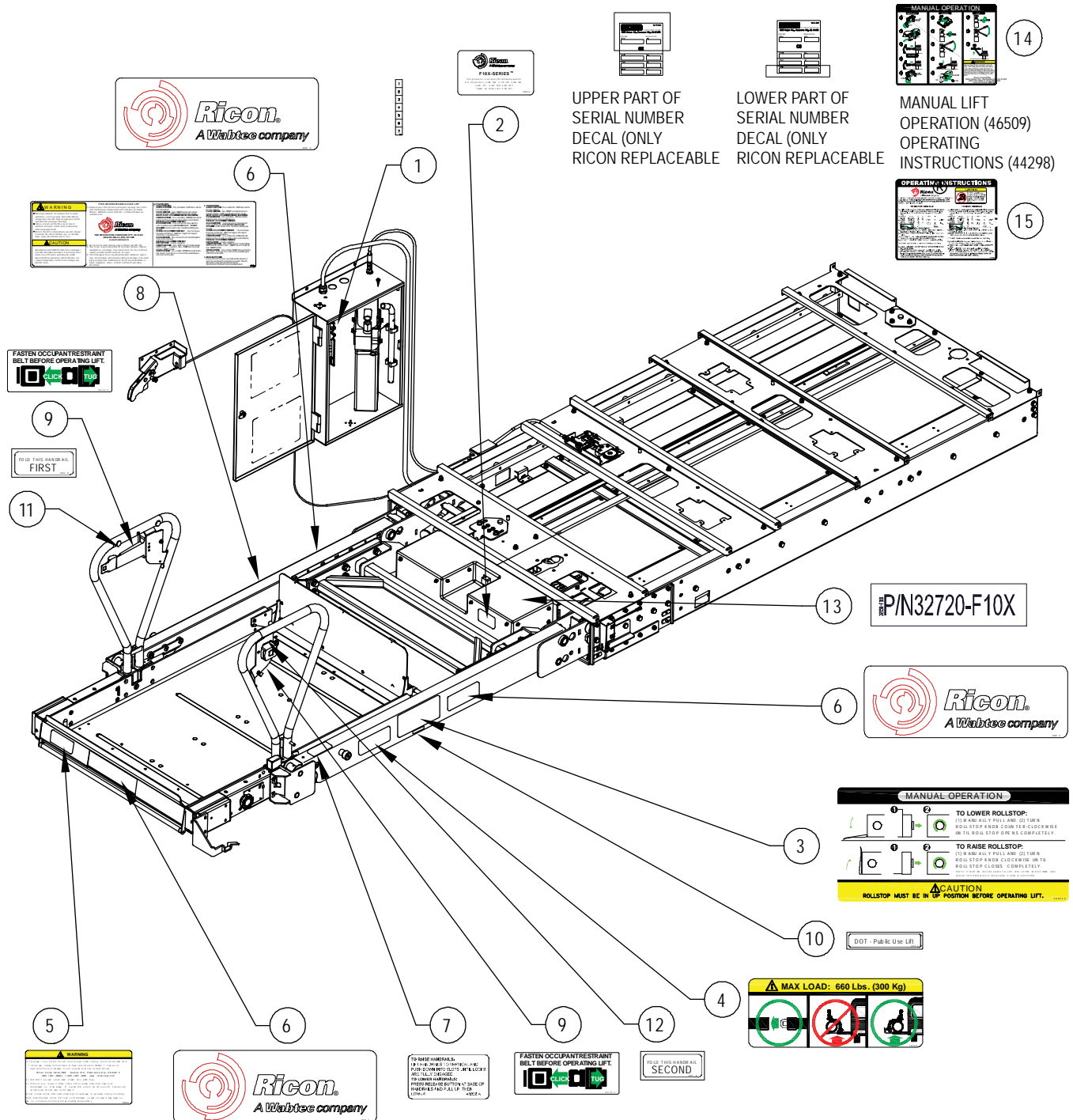

FIGURE 5-1: F10X-SERIES DECALS

RSM0031000

FIGURE 5-1: F10X-SERIES DECALS

FIG. ITEM	DESCRIPTION	QTY	CONFIG.	PART NO.
1	DECAL, 17 TERMINAL	1		15533
2	DECAL, PATENT NO'S, F10X-SERIES	1		46501
3	DECAL, ROLLSTOP MANUAL OPERATION, F10X	1		46502
4	DECAL, PROPER LOADING, 660 LBS., F10X	1		46503
5	DECAL, WARNING, IMPROPER USE-660#, F10X	1		46504
6	DECAL, RICON, HORIZ, 10.5" X 2.75", F10X	3		46505
7	DECAL, INSTR., UNFOLD HANDRAILS, F10X	1		46506
8	DECAL, OPERATOR INSTR., TRANSIT, F10X	1		46508
9	DECAL, "CAUTION" RESTRAINT BELT	1		26155
10	DECAL, DOT, PUBLIC USE LIFT	1		32113
11	DECAL, HANDRAIL, FOLD FIRST	1		34510
12	DECAL, HANDRAIL, FOLD SECOND	1		34511
13	DECAL, CONTROL BOX, NO INT SOFTWARE	1		32150-F10X
14	DECAL, MANUAL LIFT OPERATION	1		46509
15	DECAL, OPERATING INSTRUCTIONS	1		44298

NOTE: * Item or configuration not shown.

NOTE: See Decal Set P/N 46500*

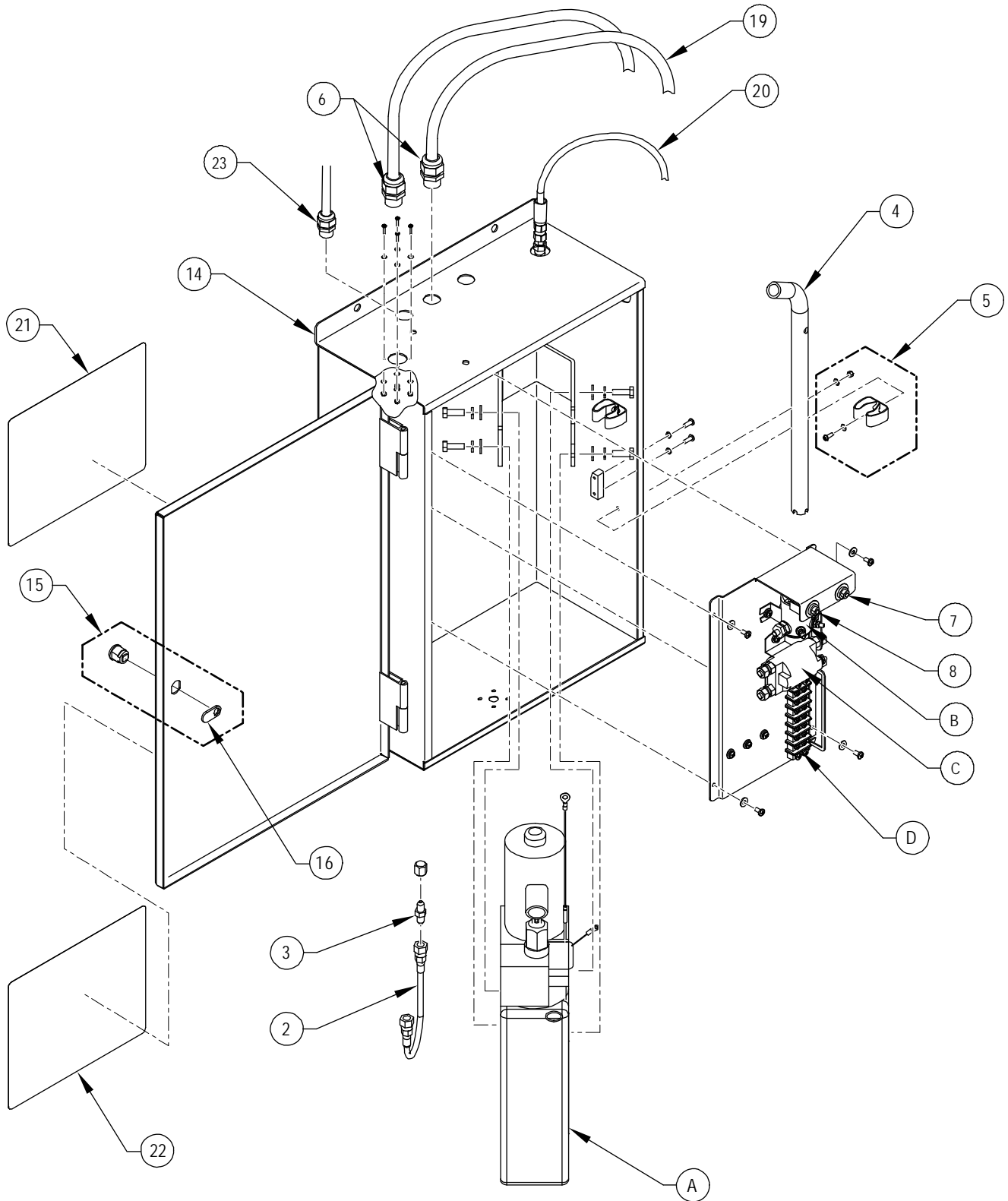
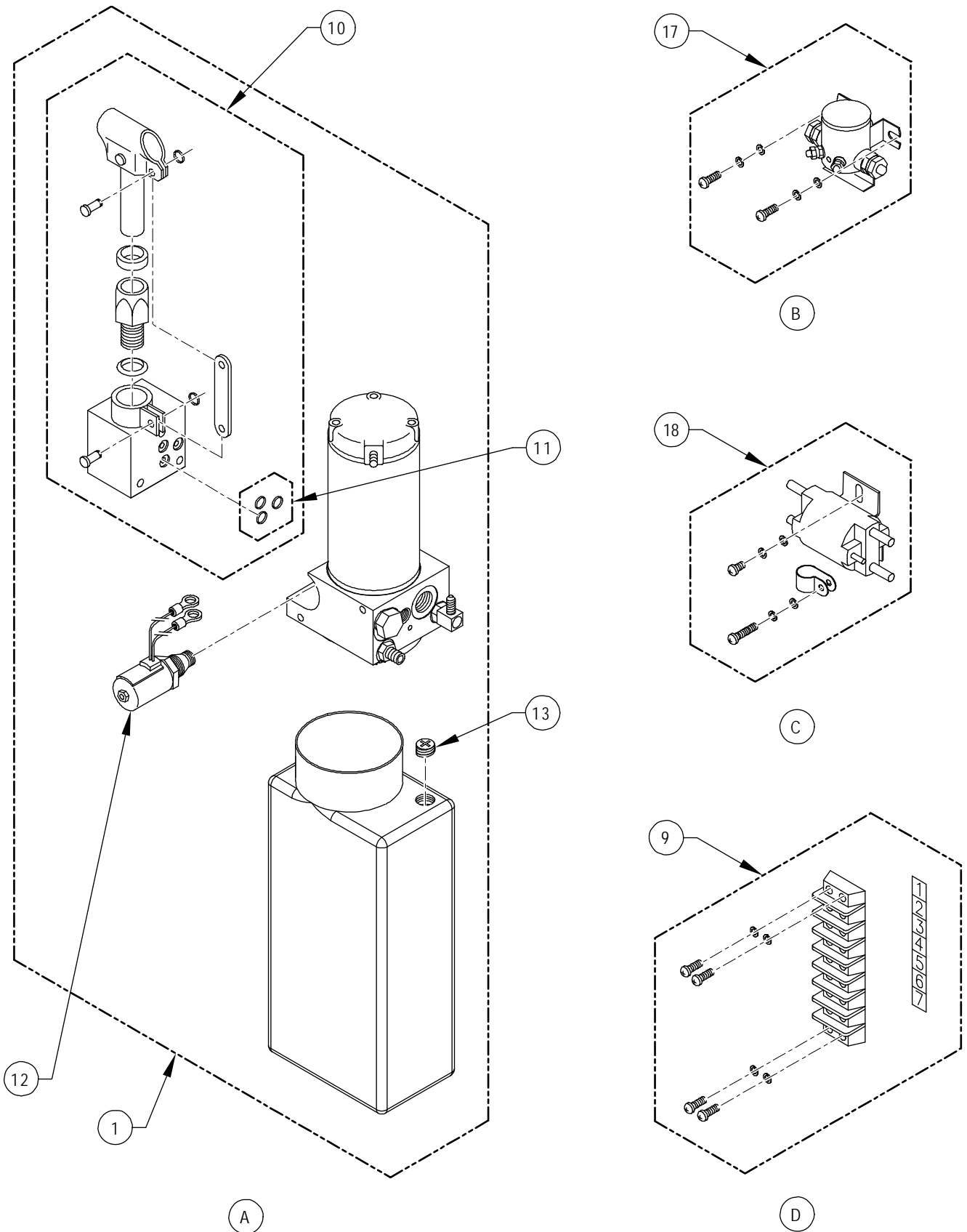

FIGURE 5-2: F10X-SERIES PUMP ASSY (LEFT HAND SIDE PUMP SHOWN) (SHEET 1 OF 2)

RSM0031501



RSM0031600

FIGURE 5-2: F10X-SERIES PUMP ASSY (LEFT HAND SIDE PUMP SHOWN) (SHEET 2 OF 2)

This page intentionally left blank.

FIGURE 5-2: F10X-SERIES PUMP ASSY

FIG. ITEM	DESCRIPTION	QTY	CONFIG.	PART NO.
1	PUMP ASSY, 1.8 KPSI, 24V, W/LARGE RESERVOIR	1		19275
2	HOSE ASSY, HYDRAULIC, 11" X 1/4 JIC X 1/4 JIC	1		F9-0333
3	FITTING, BUN, 1/4 J, 2.08L	1		V2-SH-17
4	PUMP HANDLE, MANUAL	1		15379-F10X
5	KIT, TOOL CLIP, W/RIVET	2		19557
6	STRAIN RELIEF, STRAIGHT THRU, W/NUTS	2		47379-F10X
7	CIRCUIT BREAKER, 30A	1		26510
8	CIRCUIT BREAKER, 8A	1		265108
9	KIT, TERMINAL STRIP, 7-TERM, W/ HARDWARE	1		20666
10	BACK UP PUMP ASSY, MANUAL W/O HANDLE (PM2)	1		V2-SH-210
11	SEAL KIT, PUMP, MANUAL BACK-UP	1		V2-SH-220
12	KIT, DOWN VALVE, W/TERMINALS	1		22038
13	PLUG, RESERVOIR, BREATHER	1		V2-SH-106
14	PUMP BOX	1		20991-F10X
15	KIT, PUMP BOX LOCK, W/BLOCK	1		19556
16	CAM, LOCK	1		19676
17	KIT, SOLENOID, 24V, SINGLE POLE, W/HARDWARE	1		20667
18	KIT, SOLENOID, 24V, DOUBLE POLE, W/HARDWARE	1		20669
19	HARNESS, PUMP TO CONNECTOR BRACKET	1		23920
20	HOSE, HYDRAULIC	1		23921
21	DECAL, MANUAL LIFT OPERATION	1		46509
22	DECAL, OPERATING INSTRUCTIONS	1		44298
23	STRAIN RELIEF, STRAIGHT THRU LIQUID TIGHT W/NUTS	1		26284

NOTE: (REF) in QTY column is for Referenced Parts Only and are not sold as spare parts.

NOTE: * Item or configuration not shown.

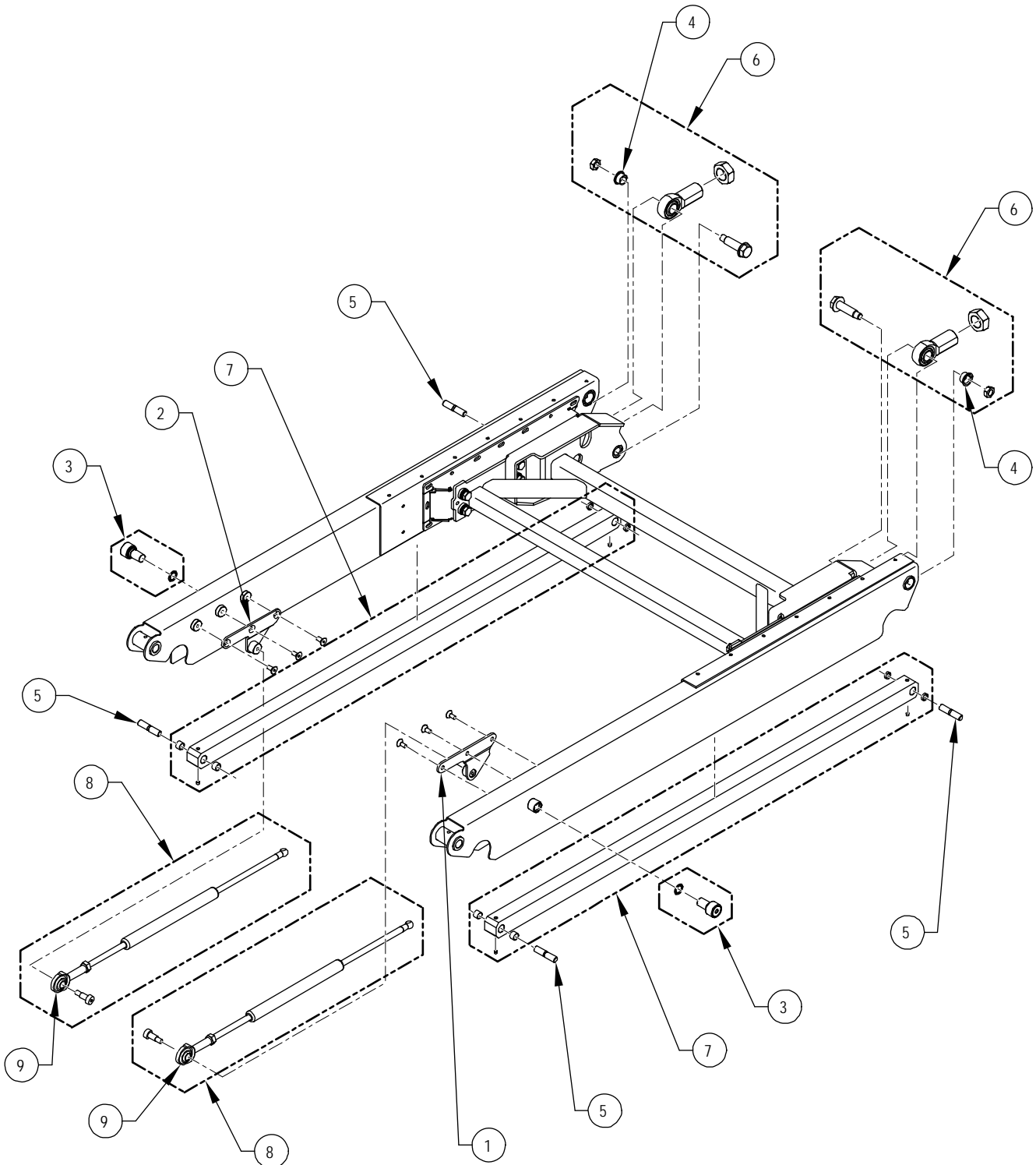

RSM0031702

FIGURE 5-3: F10X-SERIES LIFTING FRAME ASSEMBLY

FIGURE 5-3: F10X-SERIES LIFTING FRAME ASSY

FIG. ITEM	DESCRIPTION	QTY	CONFIG.	PART NO.
1	PLATE WELDMENT, B/PLATE ACTUATOR, LH	1		20977-F10X
2	PLATE WELDMENT, B/PLATE ACTUATOR, RH	1		20976-F10X
3	KIT, CAM FOLLOWER, 1.25" OD W/HARDWARE	1		46515
4	BUSHING PIVOT, HYDRAULIC CYLINER (SEE KIT 46516)	2		46110-F10X
5	PIN, PIVOT, .75 X 3.25", SST	4		19270-F10X
6	KIT, ROD END, FEMALE, 3/4", RH W/HARDWARE	2		46516
7	KIT, LOWER ARM, W/HARDWARE	2		46517
8	KIT, BRIDGEPLATE ACTUATOR, W/ROD END & HARDWARE	2		46518
9	ROD END, M10 X 14MM, M10-1.5	2		19253

NOTE: (REF) in QTY column is for Referenced Parts Only and are not sold as spare parts.

NOTE: * Item or configuration not shown.

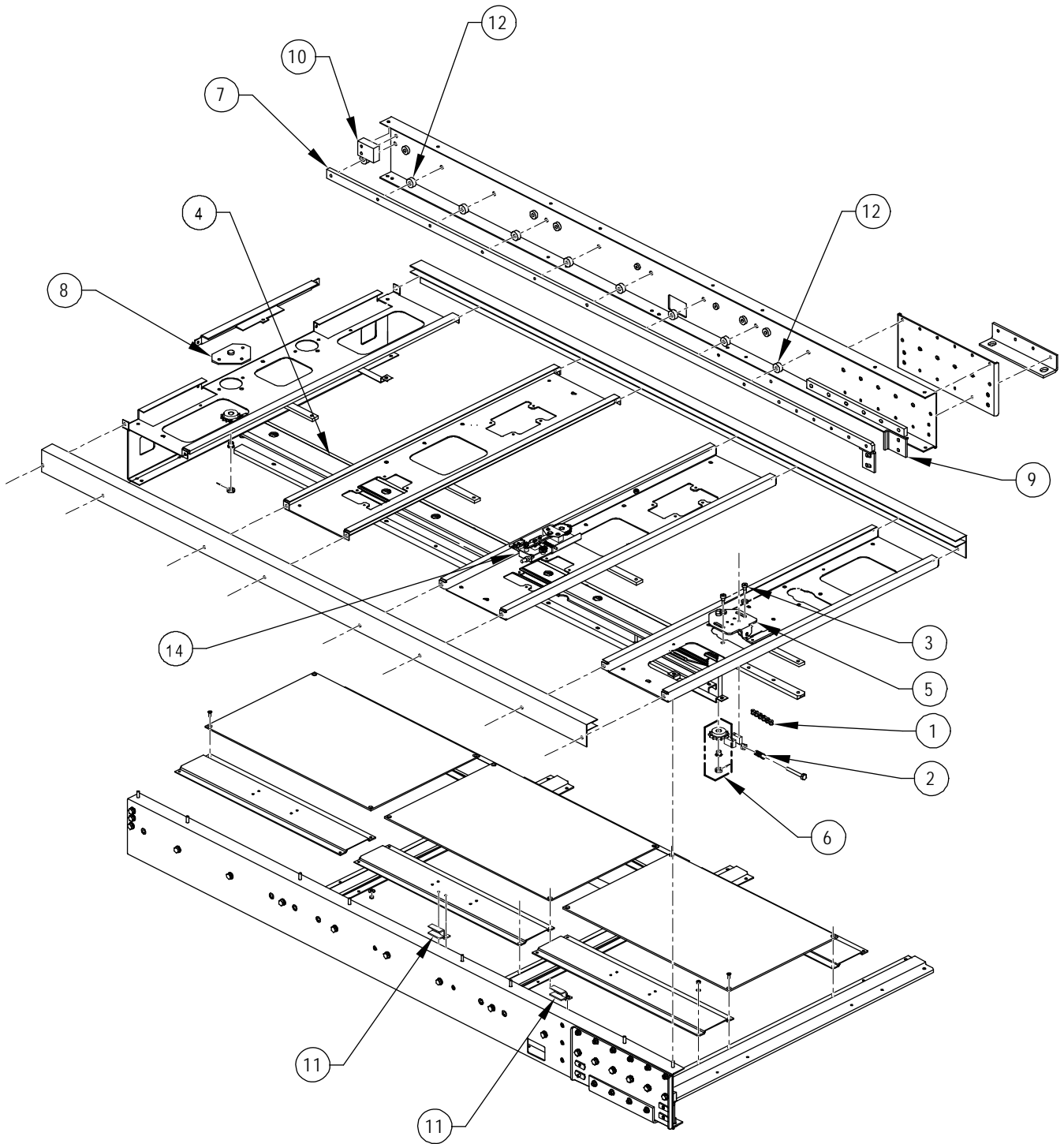

RSM0031801

FIGURE 5-4: F10X-SERIES ENCLOSURE ASSEMBLY

FIGURE 5-4: F10X-SERIES ENCLOSURE ASSY

FIG. ITEM	DESCRIPTION	QTY	CONFIG.	PART NO.
1	CHAIN, CARRIAGE DRIVE	1		20513
2	SPRING, COMP, .600D X 1.5"	1		15263
3	SCREW, SSC, M10 X12MM, M8-1.25 X 3M	4		15262
4	CHAIN TRACK	1		15227-F10X
5	PLATE, SPROCKET SUPPORT, FRONT	1		15218-F10X
6	KIT, SPROCKET, #40, 14T, W/HARDWARE	2		22013
7	GUIDE, RAIL	2		18255-F10X
8	PLATE, SPROCKET SUPPORT, REAR	1		18247-F10X
9	CARRIAGE STOP, FRONT	2		18295
10	CARRIAGE STOP, REAR	2		18256-F10X
11	CLAMP, HARNESS	2		15234-F10X
12	SPACER, GUIDE RAIL (BAG OF 10)	18		46521
13 *	KIT, INTERFACE BRACKET, W/HARDWARE, LH	1		47365
14	DRIVE LOCK ASSY	1		48107

NOTE: (REF) in QTY column is for Referenced Parts Only and are not sold as spare parts.

NOTE: * Item or configuration not shown.

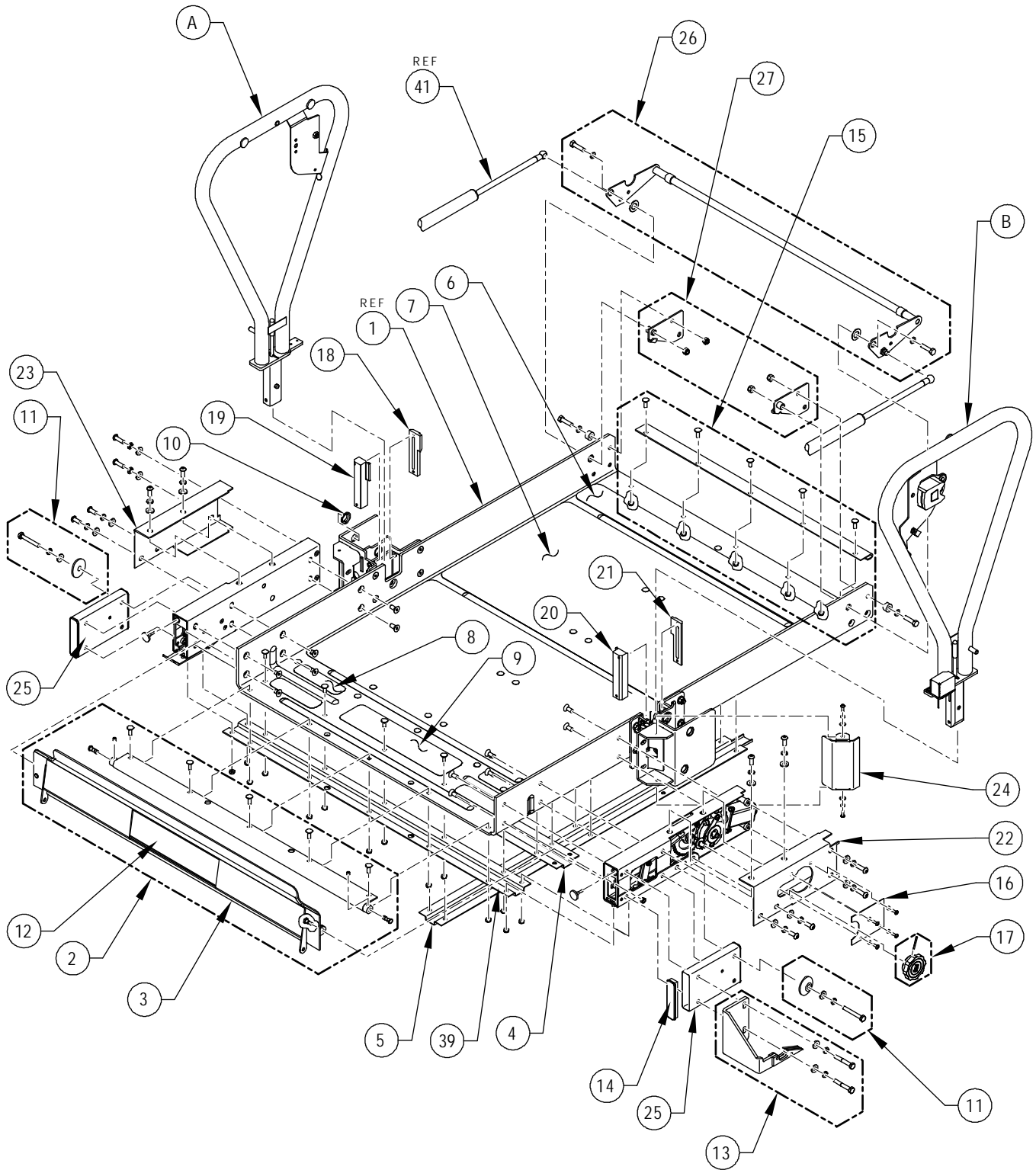

RSM0031901

FIGURE 5-5: F10X-SERIES PLATFORM ASSEMBLY (SHEET 1 OF 2)

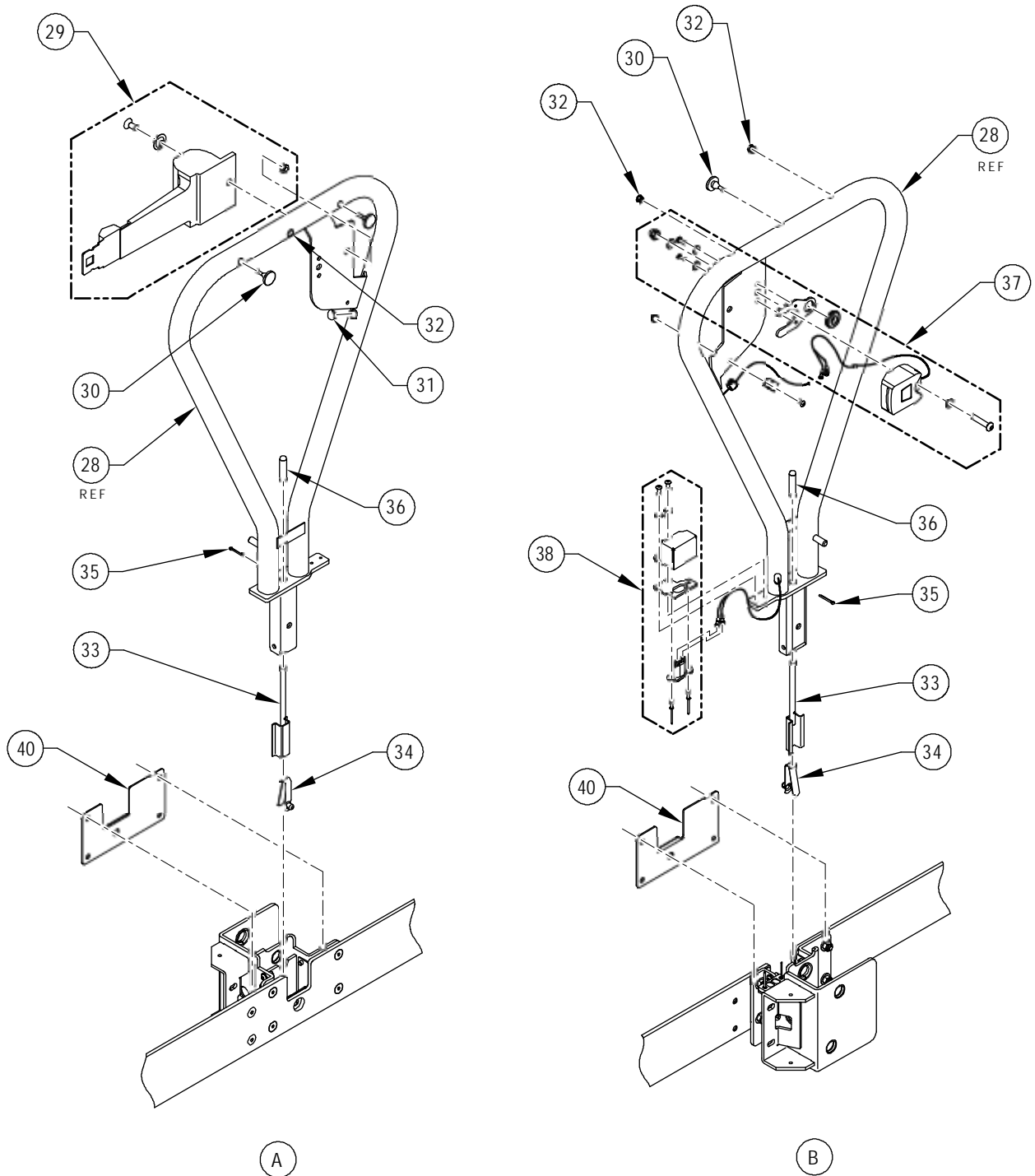

FIGURE 5-5: F10X-SERIES PLATFORM ASSEMBLY (SHEET 2 OF 2)

RSM0032001

FIGURE 5-5: F10X-SERIES PLATFORM ASSY

FIG. ITEM	DESCRIPTION	QTY	CONFIG.	PART NO.
1	PLATFORM, 32.25 X 47.00, PRS	REF		32871-F10X
2	KIT, ROLLSTOP ASSEMBLY	1		32168
3	KIT, STIFFENER, PLATFORM, FRONT	1		20622
4	CHANNEL, HARNESS CONDUIT	1		33218
5	CHANNEL, HARNESS CONDUIT	1		33217
6 *	SAFETREAD, 3.0 X 31.0, YELLOW (See Notes)	1		32987
7 *	SAFETREAD, 16.0 X 31.0, GRAY (See Notes)	1		32986
8 *	SAFETREAD, 12.75 X 3.0, YELLOW (See Notes)	1		25673
9 *	SAFETREAD, 5.5 X 1.5, YELLOW (See Notes)	4		25674
10	BEARING, FLANGED, 3/4 ID X 1/4 W, (BAG OF 10)	1		19576
11	KIT, PLATFORM GUIDE, FRONT, W/HARDWARE	2		46554
12	DECAL, RICON, HORIZ, 10.5" X 2.75", F10X	1		46505
13	STRIKER WLDT, STOWLOCK	1		44963-F10X
14	CAP, RECTANGULAR, SNAP-IN	1		22519
15	KIT, STIFFENER, PLATFORM, REAR	1		20626
16	PLATE, MANUAL RELEASE	1		32866
17	KIT, KNOB W/ROLLPIN	1		20616
18	BLOCK, HANDRAIL GUIDE, RH	1		42784-F10X
19	BLOCK, HANDRAIL GUIDE, LH	1		46103-F10X
20	BLOCK, HANDRAIL GUIDE, RH	1		46104-F10X
21	BLOCK, HANDRAIL GUIDE, LH	1		42785-F10X
22	COVER, ROLLSTOP MOTOR, RH	1		32857-F10X
23	COVER, ROLLSTOP MOTOR, LH	1		32858-F10X
24	COVER, PLATFORM BRACKET	1		46120-F10X
25	KIT, COVER, PRS, W/HARDWARE	1		22525
26	KIT, STIRRUP WELDMENT, DE, W/HARDWARE	1		20651
27	KIT, BRIDGEPLATE MOUNTING BRACKET	1		20665
28	HANDRAIL WLDT, RESTRAINT BELT INTRLOC	2		35810
29	KIT, SAFETY BELT, RETRACTABLE	1		36959
30	KIT, BUMPER, RUBBER (BAG OF 10)	1		20653
31	PLUG, W/.500 HOLE, NYL, BLK	1		28879
32	PLUG, .31DIA, .3 to .14 MTL, BLK PL (BAG OF 10)	1		35464
33	LEVER WLDT, HANDRAIL RELEASE	2		35812
34	CONNECTOR, TUBE, SPRING, .365 OD X .37H	2		33143
35	PIN, COTTER, 3/32 X 3/4, SST	2		23989
36	CAP, (.313 X 1.5) IL HEAVY BK LETTER VINYL RED	2		01651
37	KIT, SAFETY BELT BUCKLE, W/HARDWARE	1		46519
38	KIT, CONTACT CONNECTOR	1		46520
39	KIT, STIFFENER, PLATFORM, FRONT	1		UV-PF-235

NOTE: (REF) in QTY column is for Referenced Parts Only and are not sold as spare parts.

FIGURE 5-5: F10X-SERIES PLATFORM ASSY CONT'D

FIG. ITEM	DESCRIPTION	QTY	CONFIG.	PART NO.
40	KIT, PLATES, PIN LOCK, W/HARDWARE	1		34873
41	KIT, BRIDGEPLATE ACTUATOR, W/ROD END & HARDWARE	2		46518

NOTE: (REF) in QTY column is for Referenced Parts Only and are not sold as spare parts.

* Flooring is factory installed and may require additional parts for installation.

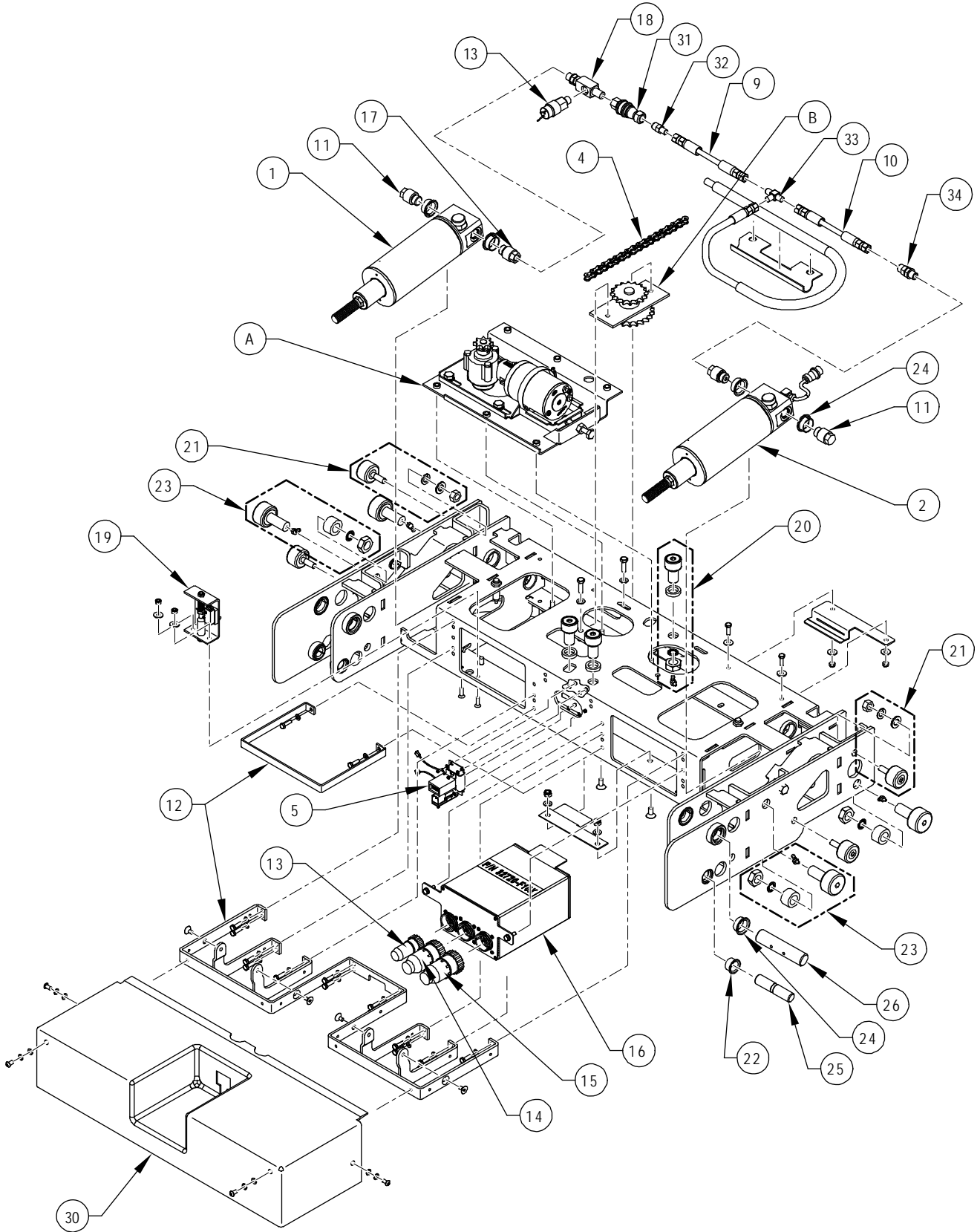

RSM0032100

FIGURE 5-6: F10X-SERIES CARRIAGE ASSEMBLY (SHEET 1 OF 2)

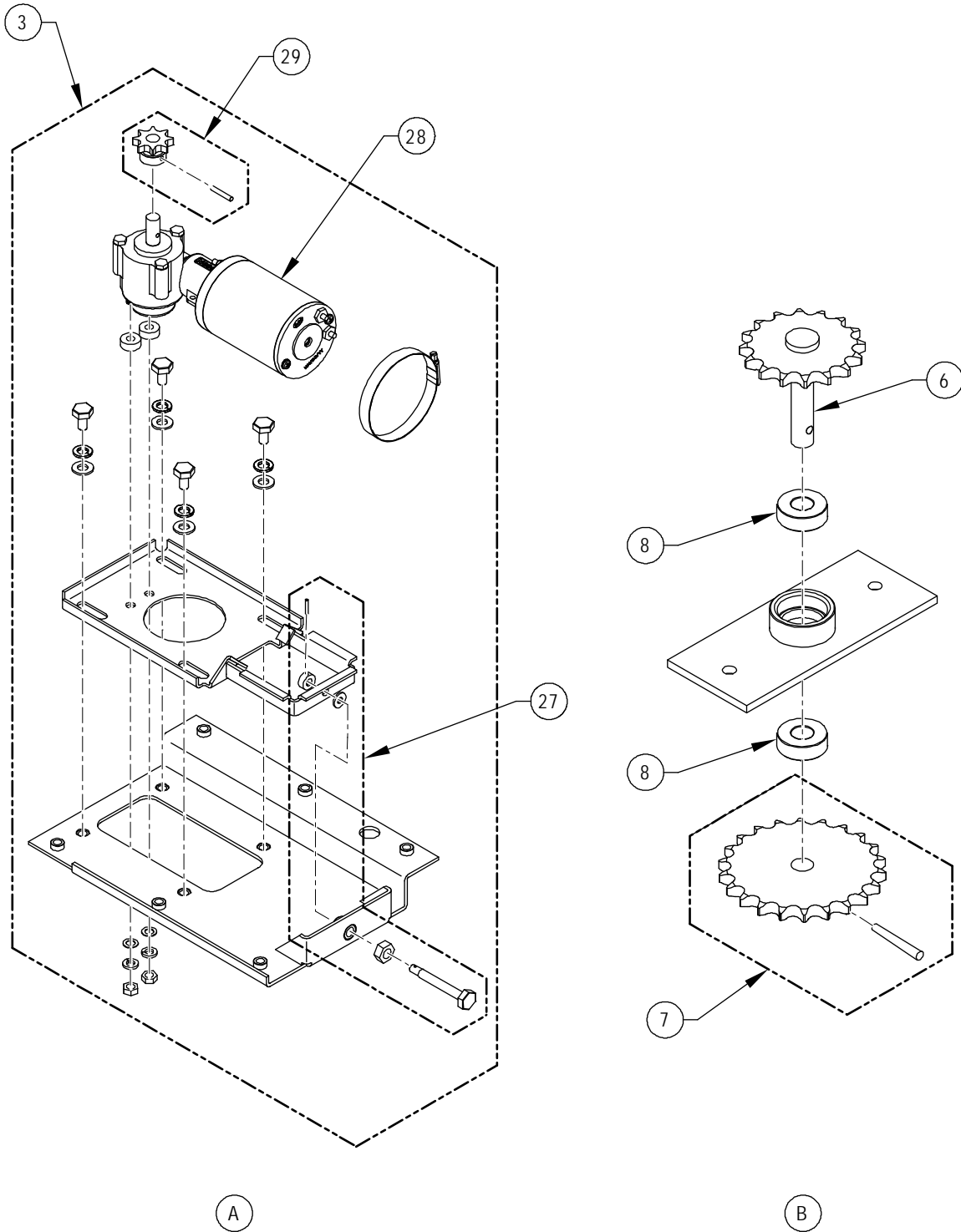

FIGURE 5-6: F10X-SERIES CARRIAGE ASSEMBLY (SHEET 2 OF 2)

RSM0032201

This page intentionally left blank.

FIGURE 5-6: F10X-SERIES CARRIAGE ASSY

FIG. ITEM	DESCRIPTION	QTY	CONFIG.	PART NO.
1	HYDRAULIC CYLINDER ASSY, W/O INTERNAL/POT	1		13095-F10X
2	HYDRAULIC CYLINDER ASSY, W/INTERNAL/POT	1		15566-F10X
3	MOTOR ASSEMBLY, LH	1		19231-F10X
4	CHAIN, DRIVE MOTOR	1		20500
5	KIT, PC BOARD, CNTR, COUNTER	1		16673
6	SHAFT WLDT, SPROCKET, DRIVE	1		15482-F10X
7	KIT, SPROCKET, 22T, #40, W/PIN	1		22015
8	BEARING, BALL, .5 BORE, 1.125 OD, .375L	1		20521
9	HOSE ASSY, HYD, 7.50" SYNDFLEX	1		46132-F10X
10	HOSE ASSY, HYD, 10.50" SYNDFLEX	1		20515-F10X
11	FITTING, PIVOT, 1/4 NPT	2		F8-0009-F10X
12	BRACKET, MOUNTING, COVER	1		19289-F10X
13	HARNESS, RES.POT & PRESS SWITCH	1		18078
14	HARNESS ASSY, SPIDER, W/POWER ROLLSTOP	1		17883-F10X
15	HARNESS, MAIN, W/HYDRAULIC	1		17882-F10X
16	CONTROL BOX ASSY, 24V, NO INTERMED SOFTWARE	1		32720-F10X
17	FITTING, PIVOT, 1/4 NPT	2		F8-0008-F10X
18	ADAPTOR, PRESSURE SWITCH, ANTI-STOW	1		17702
19	PLUNGER ASSY	1		19282
20	KIT, ROLLER, 1.25 OD X .75W, W/HARDWARE	4		22029
21	KIT, CAM FOLLOWER, 1.75 OD, W/FITTING/HARDWARE	4		22033
22	KIT, BEARING, DU, .75 ID X .50W (BAG OF 10)	1		22078
23	KIT, CAM FOLLOWER, 1.75 OD, W/FITTING/HARDWARE	1		22034
24	KIT, BEARING, DU, 1.00 ID X .50W (BAG OF 10)	1		19579
25	PIN, PIVOT, .75 X 3.25", SST	2		19270-F10X
26	PIN, PIVOT, 1.00 X 4.25", SST	2		20552-F10X
27	KIT, ADJUSTMENT SCREW, DRIVE MOTOR	1		45514
28	GEAR MOTOR ASSEMBLY	1		UV-DS-207
29	KIT, SPROCKET, 8T, #40, W/PIN	1		22028
30	COVER, CARRIAGE	1		19292-F10X
31	FITTING, QUIK DISCONNECT, 1/4"	1		19587
32	FITTING, MCN, 1/4J, 1/4P, STL (SEE KIT 19587)	1		V2-SH-84
33	TEE-JIC, 4 x 4 x 4, STL, .90 x .90 x .90	1		V2-SH-97
34	FITTING, ADAPTER, PRESSURE SWITCH	1		46134-F10X

NOTE: (REF) in QTY column is for Referenced Parts Only and are not sold as spare parts.

NOTE: * Item or configuration not shown.

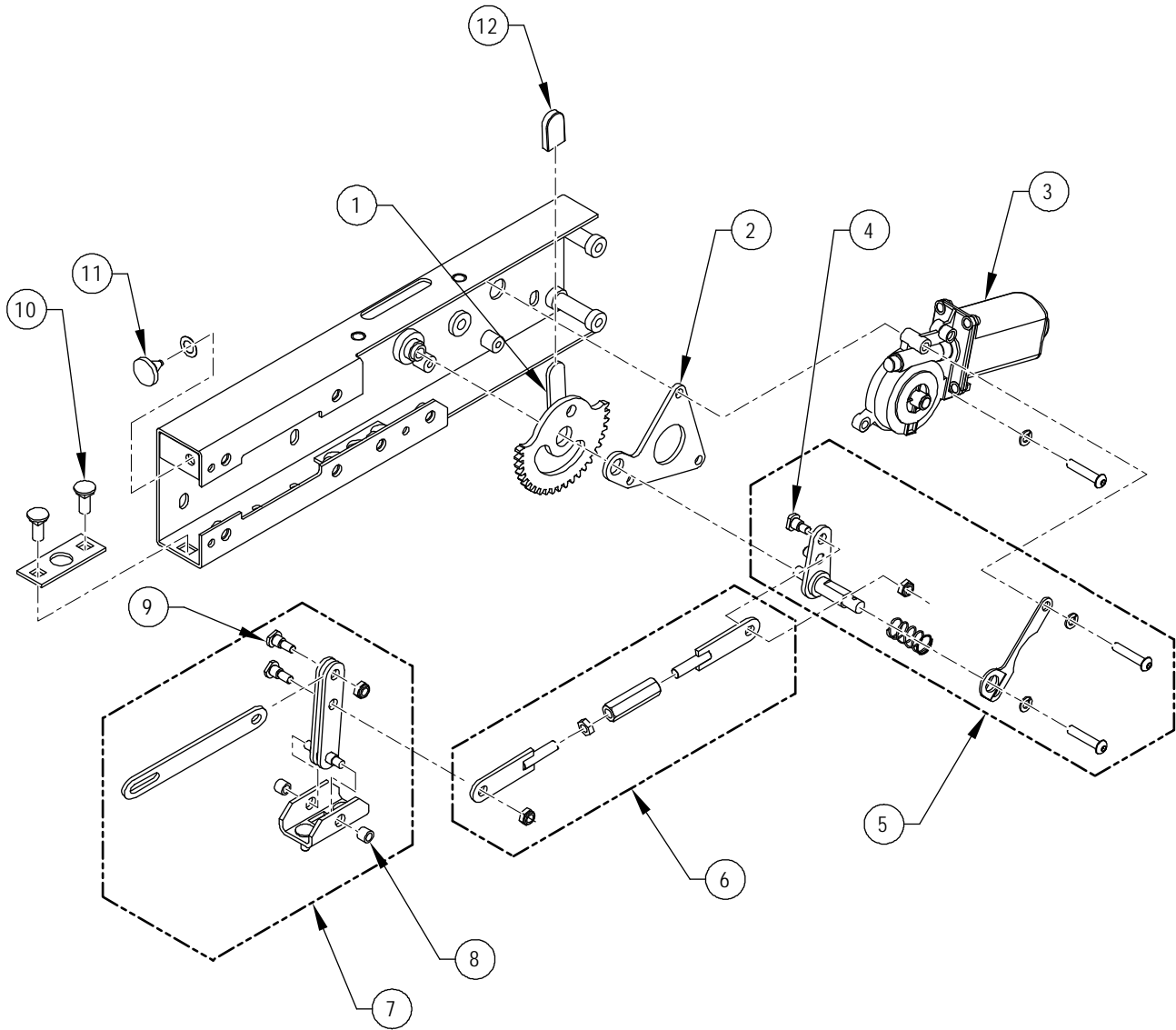

RSM0032300

FIGURE 5-7: F10X-SERIES POWER ROLLSTOP (PRS) ASSEMBLY (RIGHT SIDE)

FIGURE 5-7: F10X-SERIES POWER ROLLSTOP (PRS) ASSY (RIGHT)

FIG. ITEM	DESCRIPTION	QTY	CONFIG.	PART NO.
1	GEAR, W/INDICATOR, PRS	1		F9-0452
2	KIT, GEAR MOTOR MOUNTING PLATE	1		20611
3	KIT, GEAR MOTOR, 24V W/HARDWARE	1		20612
4	SCREW, SSC, .31 X .25, M6-1.0 X 7.9MM	1		15285
5	KIT, MANUAL RELEASE LEVER, W/HARDWARE	1		22030
6	KIT, LINK, ADJUSTABLE, W/HARDWARE	1		22031
7	KIT, COMPENSATOR LINKAGE, W/HARDWARE	1		22032
8	BUSHING, COMPENSATOR LINKAGE, PRS	2		UV-PF-883
9	SCREW, SSC, .31 X.25 M6-1.0 X 11MM	2		15286
10	SCREW, CARRIAGE, M8-1.25 X 20MM (BAG OF 10)	2		20586
11	BUMPER, RUBBER (BAG OF 10)	1		20653
12	CAP, VINYL, RED W/ARROW, .13 X .50 X 1.00	1		F8-0284

NOTE: (REF) in QTY column is for Referenced Parts Only and are not sold as spare parts.

NOTE: * Item or configuration not shown.

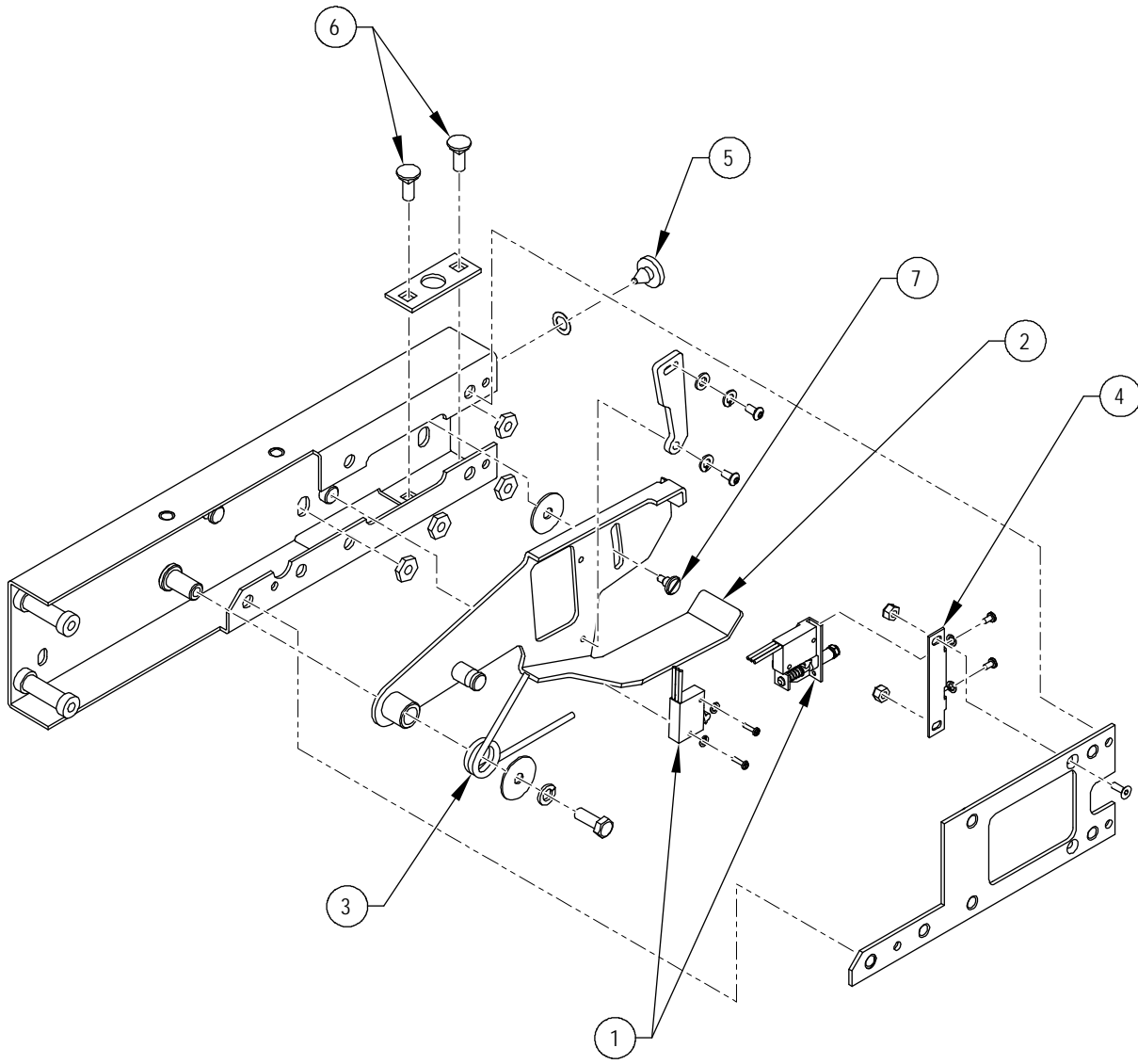

RSM0032400

FIGURE 5-8: F10X-SERIES ROLLSTOP LATCH ASSEMBLY (LEFT SIDE)

FIGURE 5-8: F10X-SERIES ROLLSTOP LATCH ASSY (LEFT)

FIG. ITEM	DESCRIPTION	QTY	CONFIG.	PART NO.
1	HARNESS, W/ROLLSTOP SWITCH & GROUND SWITCH	1		UV-ES-221
2	LATCHSKI WLDT, PRS	1		12134
3	SPRING, LH, ROLLSTOP ACTR, RETURN	1		UV-SP-002
4	BRACKET, ROLLSTOP SWITCH	1		UV-PF-911
5	BUMPER, RUBBER (BAG OF 10)	1		20653
6	SCREW, CAR, 1/4-20 x 5/8" SST(BAG OF 10)	2		19707
7	SCREW, SHOULDER, LATCH	1		UL-PF-034

NOTE: (REF) in QTY column is for Referenced Parts Only and are not sold as spare parts.

NOTE: * Item or configuration not shown.

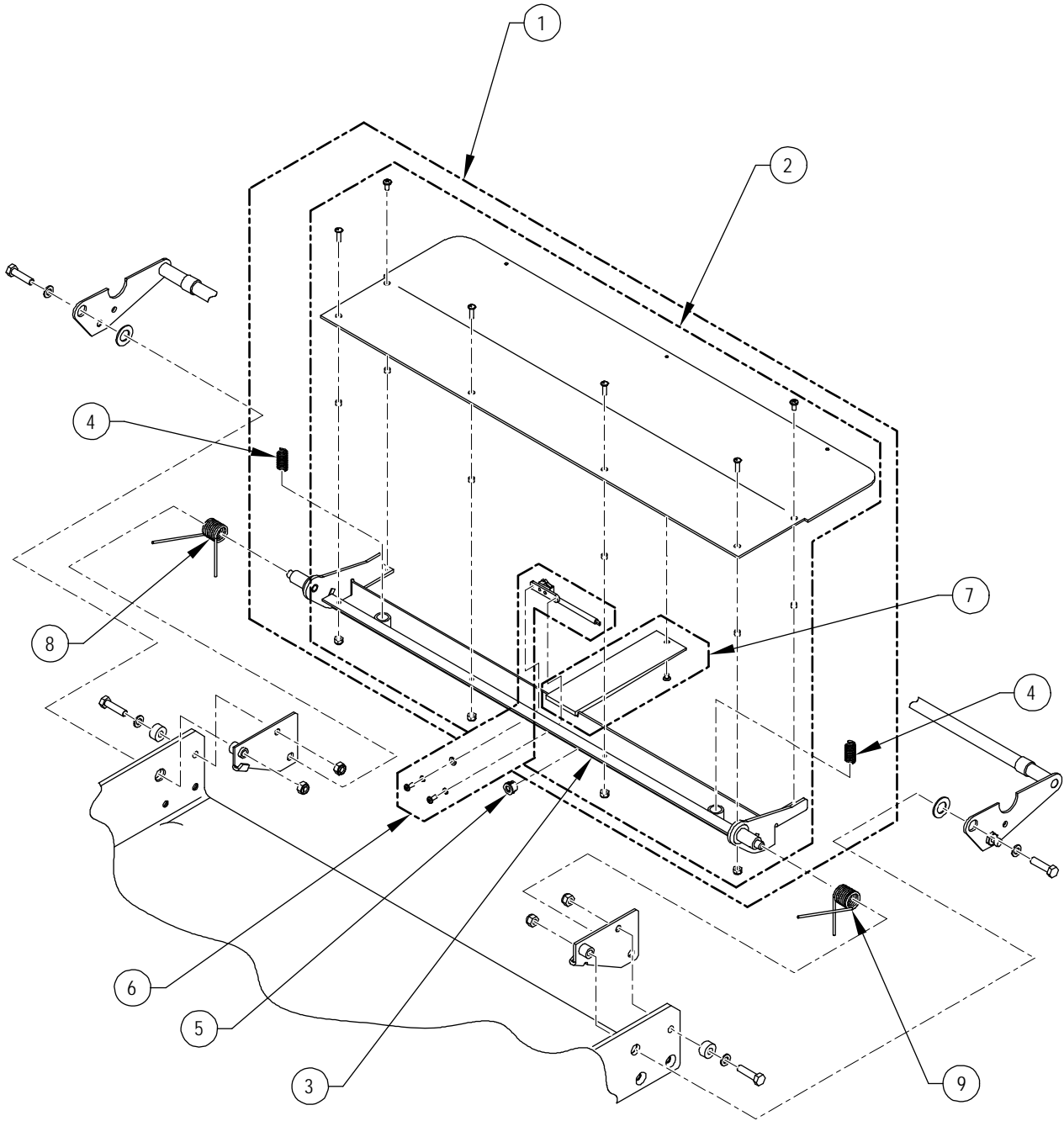

RSM0032501

FIGURE 5-9: F10X-SERIES BRIDGEPLATE ASSEMBLY

FIGURE 5-9: F10X-SERIES BRIDGEPLATE ASSY

FIG. ITEM	DESCRIPTION	QTY	CONFIG.	PART NO.
1	BRIDGEPLATE ASSEMBLY	1		38482
2	KIT, PLATE, BRIDGEPLATE, W/6 SETS OF HARDWARE	1		46555
3	FRAME WLDT, BRIDGEPLATE	1		33617
4	SPRING, COMPRESSION, SST, .48OD X .75L, .055" WIRE	2		33214
5	BUSHING, SNAP-IN, 1/2"	1		28-26-075
6	KIT, SWITCH ASSEMBLY, W/HARDWARE	1		32180
7	KIT, GUIDE, BRIDGEPLATE, W/SCREW	1		46556
8	SPRING, BRIDGEPLATE RETURN, LH	1		UV-SP-010
9	SPRING, BRIDGEPLATE RETURN, RH	1		UV-SP-011

NOTE: (REF) in QTY column is for Referenced Parts Only and are not sold as spare parts.

NOTE: * Item or configuration not shown.

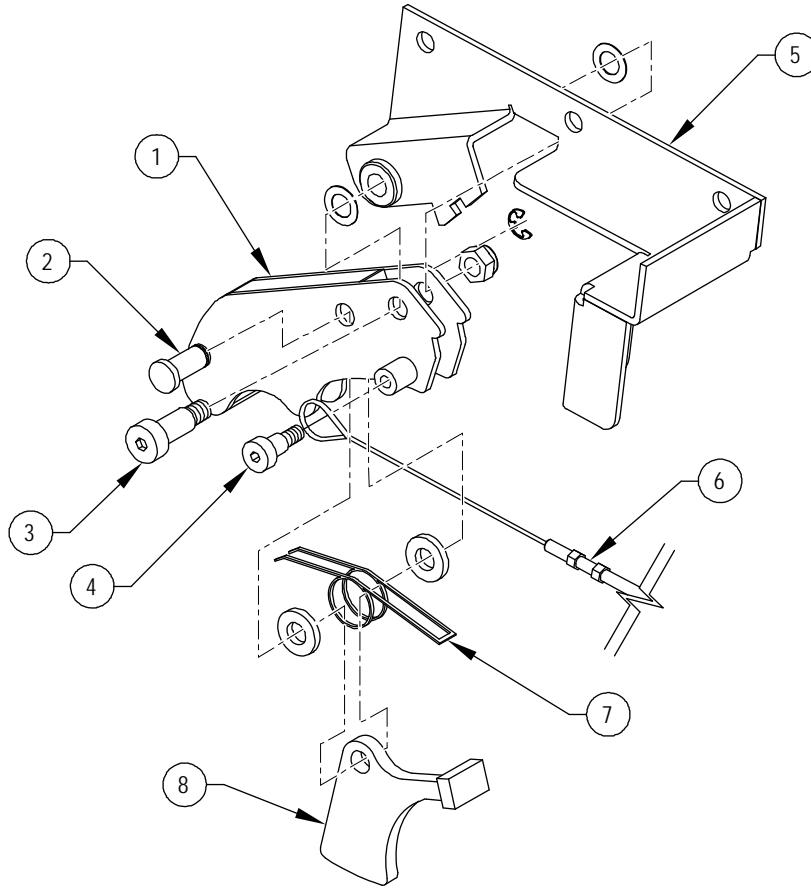

CARRIAGE RELEASE HANDLE ASSEMBLY

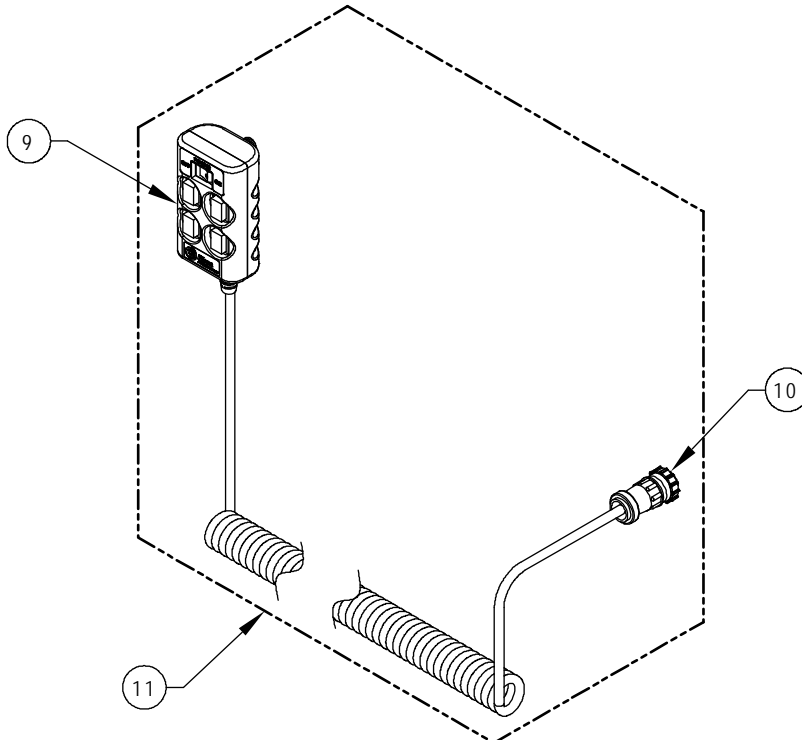

PENDANT ASSEMBLY

RSM0032600

FIGURE 5-10: F10X-SERIES CARRIAGE RELEASE HANDLE AND PENDANT ASSEMBLY

FIGURE 5-10: F10X-SERIES CARRIAGE RELEASE/PENDANT ASSY

FIG. ITEM	DESCRIPTION	QTY	CONFIG.	PART NO.
1	HANDLE WLDT, LH	1		48119
2	KIT, PIVOT PIN, TRIGGER	1		22008
3	SCREW, SHOULDER, M10X20MM, M8-1.25 X 13M	1		19225-F10X
4	SCREW, SHOULDER, M8 X 10MM, M6-1.0 X 11MM	1		19222-F10X
5	BRACKET WLDT, RELEASE, LH	1		20562-F10X
6	CABLE, CARRIAGE RELEASE	1		20959-F10X
7	SPRING, TORSION, TRIGGER	1		16030
8	TRIGGER, CARRIAGE RELEASE	1		19243-F10X
9	PENDANT ASSEMBLY (SEE ITEM 11)	1		42893
10	HARNESS, .29 DIA. COIL CORD PENDANT, 9PN ADAPTOR	1		42973
11	PENDANT ASSY, COIL CORD , 9PIN, FMVSS, BLK	1		44871

NOTE: (REF) in QTY column is for Referenced Parts Only and are not sold as spare parts.

NOTE: * Item or configuration not shown.

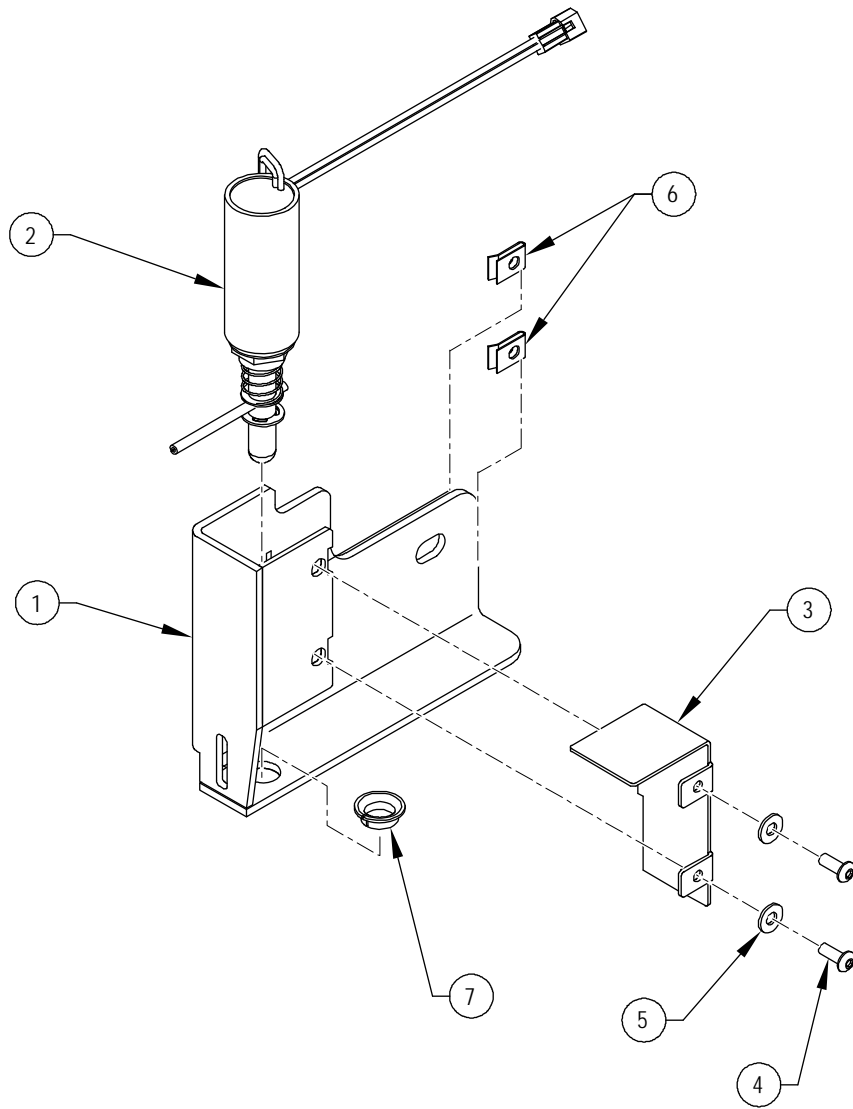

RSM0032700

FIGURE 5-11: F10X-SERIES STOW LOCK ASSEMBLY

FIGURE 5-11: F10X-SERIES STOW LOCK ASSY

FIG. ITEM	DESCRIPTION	QTY	CONFIG.	PART NO.
1	BRACKET WLDT, SOLENOID MTG, STOW LOCK	1		44947-F10X
2	SOLENOID ASSY, STOW LOCK, 24V	1		F9-0348
3	COVER, SOLENOID, STOW LOCK	1		44945-F10X
4	SCREW, BHS, 10-24 X 1/2 SST (BAG OF 10)	1		14424
5	WASHER, FLT, .219 X .50 X .049 SST (BAG OF 10)	1		14409
6	NUT, SPRING, 10-24 U TYPE (BAG OF 10)	1		11799
7	BEARING, DU FLG, 1/2 ID X 1/4L	1		253846

NOTE: (REF) in QTY column is for Referenced Parts Only and are not sold as spare parts.

NOTE: * Item or configuration not shown.

This page intentionally left blank.

APPENDIX 1

LIFT SPECIFICATIONS

F10X-SERIES MOTOR COACH WHEELCHAIR AND STANDEE LIFT

Power:
 Platform up.....electro-hydraulic
 Platform down.....gravity
 Pump rating:..... 1800psi @ 12.4 MP
 Hydraulic cylinders.....2ea, Ø3.0", single acting

Rated load capacity..... 660 lbs/300 Kg
 Manual backup-up hand pump
 Manual backup-down pressure release valve
 Lift Weight..... approx. 900 lbs

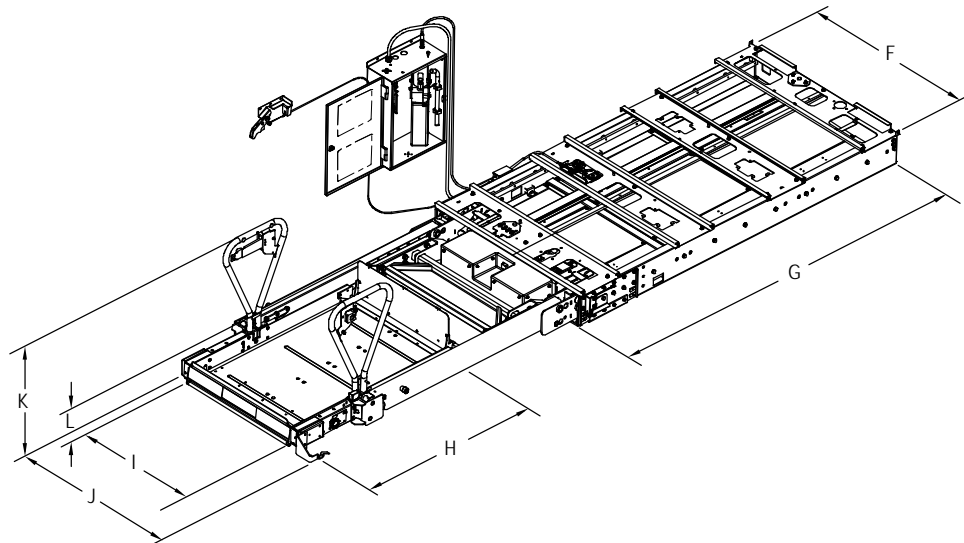
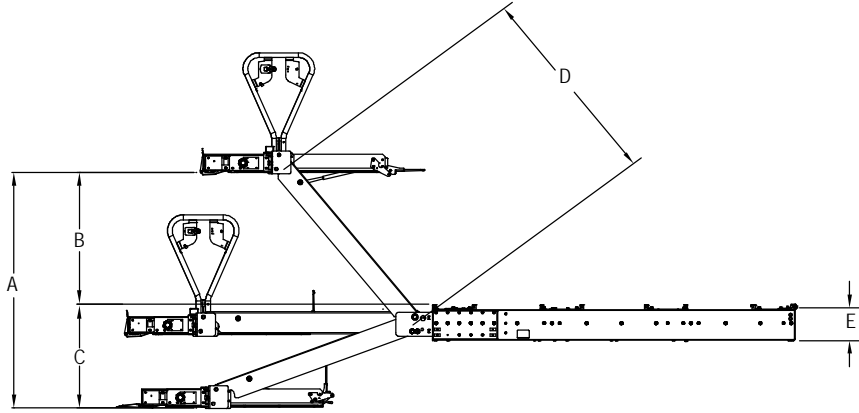

RSM0030901

DIMENSIONS – inches (millimeters)

Models	A*	B*	C*	D	E	F	G**
F10XF-0001	Floor to ground travel	Max. Travel above	Max. Travel below	Arm length	Enclosure height	Enclosure width	Enclosure length
	61.1 (1560)	34.6 (879)	26.7 (678)	52.7 (1339)	9.4 (239)	49.3 (1252)	91.0 (2311)
	H	I	J	K	L		
	Usable platform length	Usable platform width	Traveling frame width	Handrail height	Bridgeplate height		
	48.0 (1219)	30.0 (762)	46.0 (1168)	30.0 (762)	12.2 (310)		

* Note: Additional travel is possible up to the following maximums pending applications engineering:
 A = 72.0 (1829); B = 35.5 (902); C = 40.5 (1029)

** Note: The overall length of the unit is slightly longer than the enclosure length by the amount the Sto-Loc™ hook extends beyond the front end of the enclosure .75in (19.05mm) when the lift is stowed.

NOTES: