

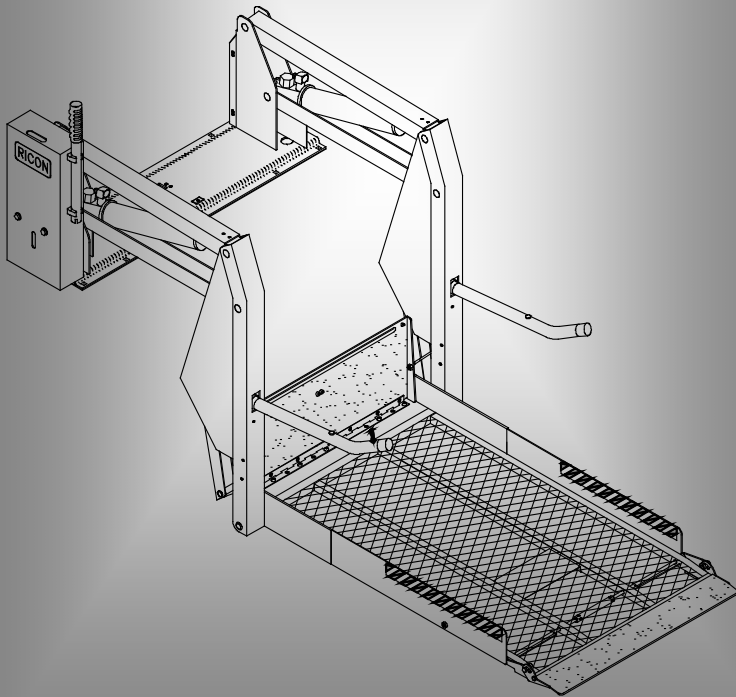

Ricon[®]

A Wabtec subsidiary

S-SERIES[®] **Wheelchair Lift for** **DOT- PRIVATE USE LIFTS**



Operator Manual

<http://ricondealer.wabtec.com>

09/04/20

32DSSP05.D

©2020 RICON CORPORATION

All Rights Reserved

U.S. Patent Nos: 4,534,450; 5,308,215; 5,445,488; 5,605,431; 5,944,473
Australian Patent No: 661127; 687,066 Canadian Patent No: 1,245,603; 2,168,761
Other U.S. and foreign patents pending.
Printed in the United States of America

This RICON product must be installed and serviced by a Ricon dealer or qualified service technicians.

The owner must refer to this manual for operating instructions, then retain it for future reference by Ricon dealers or qualified service technicians that perform maintenance.

“DOT – Private Use Lift” verifies that this platform lift meets only the private use lift requirements of FMVSS no. 403. This lift may be installed on all vehicles appropriate for the size and weight of the lift, except for buses, school buses, and multi-purpose passenger vehicles other than motor homes with a gross vehicle weight rating (GVWR) that exceeds 10,000 lbs (4,536 kgs).

Customer Information	
Customer name	
Installing dealer	
Date installed	
Serial number	

REVISION RECORD

REV	PAGES	DESCRIPTION OF CHANGE	ECO
32DSSP05. C	Cover	Update to registered trademark.	6560
	i	Update to customer information.	
	1-1	Update to registered trademark.	
	1-2	Update to Product Warranty literature.	
	2-1	Update to registered trademark.	
	2-1	Update to Safety Precaution instructions.	
	2-1	Update to Figure 2-2 caption.	
	2-2	Update to VMI contact.	
	2-6	Update to VMI contact.	
	2-9	Update to Normal Lift Operation Warning.	
	3-1	Update to registered trademark.	
	3-1	Update to Maintenance Information Warning.	
	END OF LIST		

REV	PAGES	DESCRIPTION OF CHANGE	ECO
32DSSP05. D	-	Revised document to align with new private product-line marketing	6560
	Cover	Update logo and version of manual	
	1-1	Update address, website	
	2-10	Update to RICON contact.	
	3-3	Update to Figure 3-1	
END OF LIST			

TABLE OF CONTENTS

<u>Chapter:</u>	<u>Page</u>
I. INTRODUCTION	1-1
A. PRODUCT SUPPORT	1-1
B. PRODUCT WARRANTY	1-2
C. SHIPMENT INFORMATION	1-3
D. GENERAL SAFETY PRECAUTIONS	1-3
E. MAJOR LIFT COMPONENTS	1-4
F. PLATFORM OPERATING VOLUME	1-6
II. OPERATING INSTRUCTIONS	2-1
A. SAFETY PRECAUTIONS	2-1
B. DAILY SAFETY CHECK	2-2
C. PLATFORM MOTIONS	2-3
D. CONTROLS AND INDICATORS	2-4
• CONTROL PENDANT	2-4
• CONTROL SWITCH	2-5
• CIRCUIT BREAKERS AND INDICATOR LIGHTS	2-5
• BRIDGEPLATE LOAD SENSOR	2-6
• THRESHOLD SAFETY SYSTEM	2-7
• MANUAL BACK-UP PUMP	2-7
• LIFT CYCLE COUNTER	2-8
E. NORMAL LIFT OPERATION	2-9
1. ENTERING VEHICLE	2-9
2. EXITING VEHICLE	2-10
3. STOWING PLATFORM	2-10
F. MANUAL OPERATION	2-11
1. DEPLOY PLATFORM	2-11
2. LOWER PLATFORM	2-13
3. STOW PLATFORM	2-13
G. MAINTENANCE AND REPAIR NOTE	2-13
III. MAINTENANCE	3-1
A. ADDITIONAL MAINTENANCE INFORMATION	3-1
B. CLEANING	3-1
C. MAINTENANCE SCHEDULE	3-1
D. DECAL PART NUMBERS AND LOCATIONS	3-3

This page intentionally left blank.

I. S-SERIES® PRIVATE USE LIFT INTRODUCTION

This manual provides operating and maintenance instructions for the Ricon Corporation (RICON) S-Series® Private Use wheelchair lift.

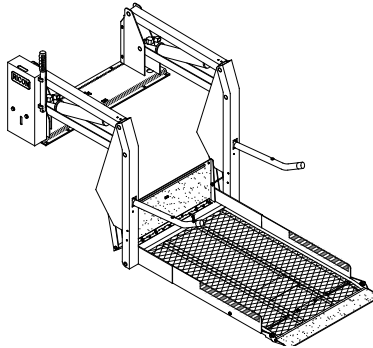

The lift is intended to provide wheelchair access to personal vehicles and to motor homes. The mechanical linkages provide smooth movement to the platform, which has a rated load capacity of 600 pounds (273 kilograms). The lift can be operated by the wheelchair occupant or by a trained assistant.

The lift contains a powerful electro-hydraulic pump with a built-in manual backup pump. If the lift loses electrical power, it can still be raised or lowered manually.

Control switches are used to unfold the lift out of the vehicle (deploy). The passenger boards the large non-skid platform and the operator uses the control switches to lower the platform to the ground. After passenger departs, the platform is raised to floor level and folded back into vehicle (stowed). Once stowed the platform is held in place by a stow lock mechanism to prevent it from drifting outward during vehicle travel.

The lift is also available with a platform that splits and folds when the lift is stowed, which provides vehicle access through the area where the lift is installed.

This manual contains warranty information, safety precautions, and operating instructions for the lift. It is important to user safety that lift operators be completely familiar with the Operating Instructions chapter of this manual. Once lift is installed, it is very important that lift be properly maintained by following the Ricon recommended cleaning, lubrication, and inspection instructions given in Chapter III, "Maintenance".

A. PRODUCT SUPPORT

If there are questions about this manual, or additional copies are needed, please contact Ricon Product Support at one of the following locations:

- Ricon Corp**
- 1135 Aviation Place**
- San Fernando, CA 91340 (800) 322-2884**
- World Wide Website www.riconcorp.com**

B. PRODUCT WARRANTY

RICON CORPORATION S-SERIES® PRIVATE USE WHEELCHAIR LIFT FIVE-YEAR LIMITED WARRANTY

Ricon Corporation (RICON) warrants to original purchaser of this product that Ricon will repair or replace, at its option, any part that fails due to defective material or workmanship as follows:

- Repair or replace parts for a period of one year from date of purchase.
- Labor costs for specified parts replace under this warranty for a period of one year from date of purchase. A Ricon rate schedule determines the parts covered and labor allowed.
- Repair or replace lift power train parts for a period of five years from date of purchase. A list of parts covered can be obtained from your Ricon dealer or Ricon product support.

If you need to return a product: Return this Ricon product to the installing dealer. Please give advance notice, and allow time for repairs.

If you are traveling: Ricon dealers honor this warranty. Consult telephone directory or call our product support department for the name of the nearest Ricon dealer or qualified service technician.

This warranty does not cover:

- Malfunction or damage to product parts caused by accident, misuse, lack of proper maintenance, neglect, improper adjustment, modification, alteration, the mechanical condition of vehicle, road hazards, overloading, failure to follow operating instructions, or acts of nature (i.e., weather, lightning, flood).

Note: Ricon recommends that this product be inspected by a Ricon dealer or qualified service technician at least once every six months, or sooner if necessary. Any required maintenance should be performed at that time.



WARNING

THIS PRODUCT HAS BEEN DESIGNED AND MANUFACTURED TO EXACT SPECIFICATIONS.
MODIFICATION OF THIS PRODUCT IN ANY RESPECT CAN BE DANGEROUS.

This warranty is void if:

- The product has been installed or maintained by someone other than a Ricon dealer or qualified service technician.
- The product has been modified or altered in any respect from its original design without written authorization by Ricon.

Ricon disclaims liability for any personal injury or property damage that results from operation of a Ricon product that has been modified from the original RICON design. No person or company is authorized to change the design of this Ricon product without written authorization by Ricon.

Ricon's obligation under this warranty is exclusively limited to the repair or exchange of parts that fail within the applicable warranty period.

Ricon assumes no responsibility for expenses or damages, including incidental or consequential damages. Some states do not allow the exclusion or limitation of incidental or consequential damages, so the above limitation or exclusion may not apply.

Important: The warranty registration card must be completed and returned to Ricon within 20 days after installation of this Ricon product for the warranty to be valid. The warranty is not transferable.

The warranty gives specific legal rights, and there may be other rights that vary from state to state.

C. SHIPMENT INFORMATION

This product is not sold directly to the user because of its specialized nature. The product is distributed through a worldwide network of Ricon dealers or qualified service technicians, who perform the actual installation.

- When the product is received, unpack it and check for freight damage. Claims for any damage should be made to freight carrier immediately.
- Be sure installation kit contains all items listed on kit packing list. Please report any missing items immediately to Ricon Product Support.
- The warranty and owner registration cards must be completed and returned to Ricon within 20 days to validate warranty. This information can also be entered in the table located on the first page of this manual.

NOTE: The Sales or Service personnel must review the Warranty and Operator Manual with the user to verify they understand how to safely operate the product. Instruct user to follow operating instructions without exception.

D. GENERAL SAFETY PRECAUTIONS

The following general safety precautions must be followed during operation:

- To avoid injury, always exercise caution when operating and be certain that hands, feet, legs, and clothing are not in path of product movement.
- Read and thoroughly understand operating instructions before attempting to operate.
- Inspect product before each use. If an unsafe condition, unusual noises or movements exist, do not use it until problem is corrected.
- Stand clear of doors and platform and keep others clear during operation.
- The product requires regular periodic maintenance. A thorough inspection is recommended at least once every six months. The product should be maintained at the highest level of performance.

E. MAJOR LIFT COMPONENTS

The references used throughout this manual are illustrated in **Figure 1-1** and defined in **Table 1-1**. Refer to the Service Manual, Chapter IV, "Parts Diagrams and Lists" for more details.

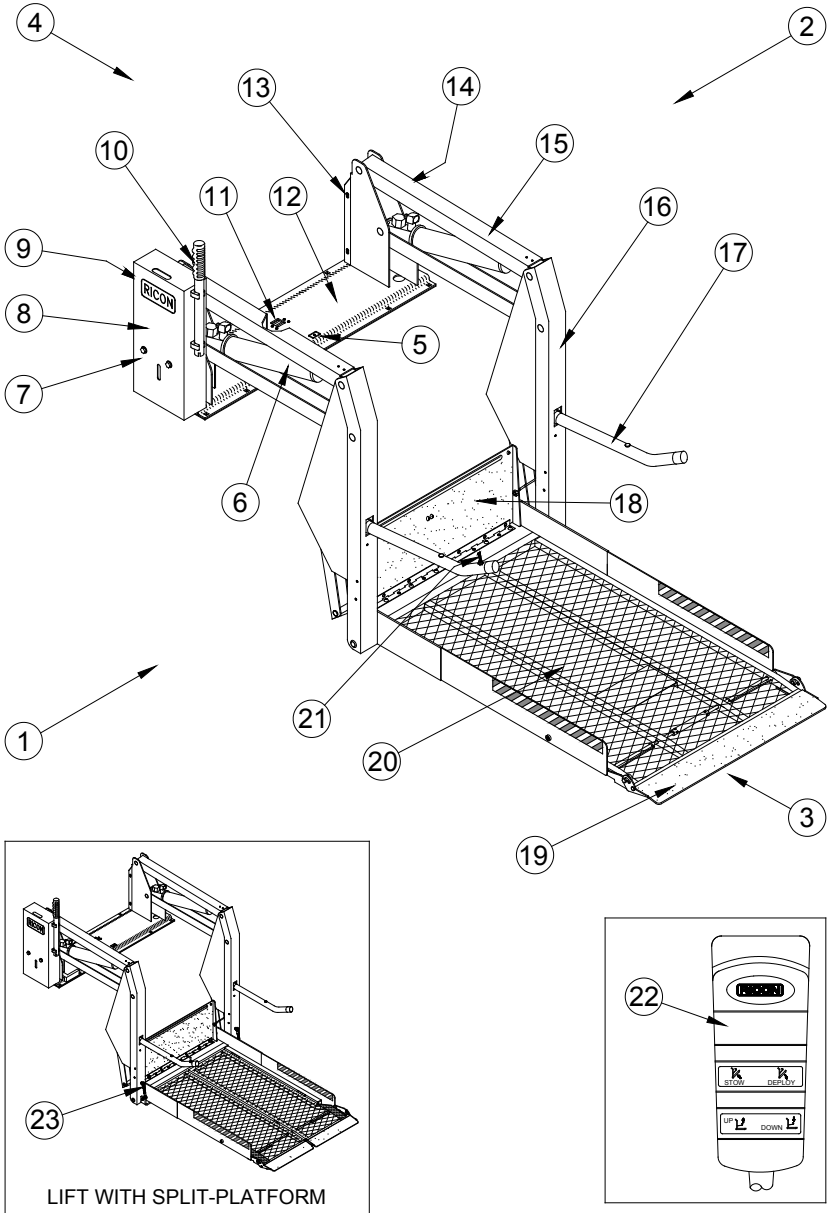

FIGURE 1-1: PRIVATE USE WHEELCHAIR LIFT COMPONENTS

TABLE 1-1: S-SERIES PRIVATE USE LIFT COMPONENT TERMS

REF	NAME	DESCRIPTION
1, 2, 3, 4	Left, right, front, back	Position references when installed lift is viewed from outside of vehicle.
5	Bridgeplate load sensor	Senses if weight is present on the lowered bridgeplate.
6	Hydraulic cylinder	(left and right) Telescoping single-acting cylinders convert hydraulic pressure into platform lifting and folding force.
7	Hydraulic power unit	Contains hydraulic pump driven by electric motor that produces pressure to raise and fold platform, and a pressure release valve to unfold and lower it.
8	Audible alarm	(inside hydraulic unit housing) Announces when something has passed over threshold. Activated by threshold beam.
9	Cycle counter	Visible at top rear of housing, it records number of times platform has moved from floor to ground and back to floor.
10	Manual backup pump handle	Used to operate manual back up-pump (located on hydraulic power unit cover).
11	Stow-Lock catch	Engages latch located on bottom of bridgeplate when platform is fully stowed.
12	Baseplate	Bolts to vehicle floor; provides secure foundation for lift structure.
13	Threshold beam	Light-beams detect presence of objects in threshold area.
14	Serial number	Location of lift serial number decal.
15	Top and bottom arms	(left and right) Upper and lower links that connect vertical arms to baseplate.
16	Vertical arm	(left and right) Connects platform to top and bottom arms.
17	Armrest	(left and right) Provide a handhold for platform occupant.
18	Bridgeplate (inboard rollstop)	Plate bridges gap between platform and baseplate when platform is at floor level. Acts as barrier to prevent wheelchair from rolling off of the platform during "Up" and "Down" platform motions.
19	Front rollstop	Front barrier prevents wheelchair from inadvertently rolling off of platform during platform movement.
20	Platform	Component of lift where wheelchair and occupant are situated during "Up" and "Down" operations.
21	Armrest switch	Allows passenger to control "Up" and "Down" platform motions.
22	Control pendant	Hand-held device controls platform motions.
23	Tie-rod	(left and right) Links on split platform models that cause platform halves to divide as platform stows.
END OF TABLE		

F. PLATFORM OPERATING VOLUME

Refer to **Figure 1-2**. The useful lift operating volume is represented in the figure by the rectangular volume shown in phantom outline. It is centered above the platform. Refer to **Table 1-2** for the dimensions that correspond to your lift model.

UNOBSTRUCTED PLATFORM
OPERATING VOLUME

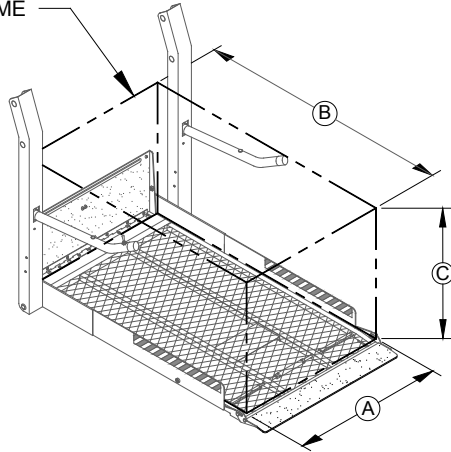

FIGURE 1-2: PLATFORM OPERATING VOLUME

TABLE 1-2: S-SERIES OPERATING VOLUME DIMENSIONS, inches (mm's)			
MODEL	A	B	C
S1231	30 (762)	42 (1,067)	30 (762)
S2003	30 (762)	51 (1,295)	30 (762)
S2005	32 (813)	51 (1,295)	30 (762)
S5003	30 (762)	51 (1,295)	30 (762)
S5005	32 (813)	51 (1,295)	30 (762)
S5010	34 (864)	56 (1,422)	30 (762)
END OF TABLE			

II. S-SERIES® PRIVATE USE LIFT OPERATING INSTRUCTIONS

This chapter contains safety precautions, daily safety check instructions, control and indicator descriptions, and operating instructions for the Ricon S-Series® Private Use wheelchair lift.

This chapter must be thoroughly understood by operator before using lift.

A. SAFETY PRECAUTIONS

The following safety precautions must be complied with at all times when operating lift:

- Refer to **Figure 2-1**. Deploying the lift when vehicle is on sloped ground is hazardous. Operate lift with vehicle parked on level ground.

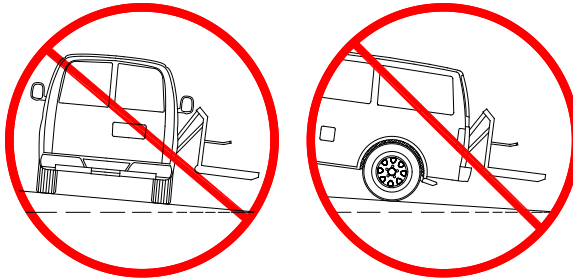

FIGURE 2-1: SLOPED PARKING HAZARD

- Vehicle must be safely parked with parking brake set before using lift.
- Inspect lift before use. Do not use lift if an unsafe condition exists, or unusual noises or movements are noticed, and contact a Ricon dealer or qualified service technician for repair.
- Read and comply with all warning labels and symbols affixed to wheelchair lift.
- Refer to **Figure 2-2**. Wheelchair occupant must face outward on platform when entering or exiting vehicle. Due to variations in size and configuration of mobility aids, for maximum safety, Ricon requires that passengers always face outward.



FIGURE 2-2: ALWAYS FACE OUTWARD WHEN RIDING ON THE LIFT PLATFORM

- It is never safe for a wheelchair occupant to exit a vehicle facing inboard. It is not safe to rely on a threshold warning device (audible, or other) to confirm that it is safe to exit while facing inboard. Exiting the vehicle while facing outboard allows for visual confirmation that the lift platform has been raised in the event that the threshold warning device is inoperative or unheard, and prevents the occupant from exiting the vehicle backwards when the platform is still on the ground.
- When exiting vehicle, verify that platform is at same height as floor and front rollstop is up

and locked.

- Do not place large equipment or furniture inside vehicle that can prevent pivoting of your wheelchair. Being able to pivot assures that you can safely exit facing outward.
- The raised front rollstop prevents slow and unintentional rolling off of the platform. It is not intended to stop a fast-moving wheelchair, which might tip forward if the small front wheels collide with the rollstop.
- Be certain wheelchair fits safely on platform; it must not extend beyond edges or interfere with operation of front rollstop.
- Do not operate with a load in excess of 600 lbs (273 kgs).
- Keep arms, legs, and clothing away from moving lift parts.
- The lift is intended for one wheelchair and its occupant. It is not designed to transport standing passengers. Do not overload lift.
- Refer to **Figure 2-3**. Do not stand in front of lift while deploying platform.



FIGURE 2-3: STAND CLEAR OF PLATFORM

- Keep others clear while operating lift.
- Do not allow an untrained person to operate lift.
- Careful supervision is necessary if used by or near children.
- Do not allow anyone to stand on bridgeplate. A bent bridgeplate can interfere with the platform as it rises and lowers.
- Lock wheelchair brakes when on platform (power chair users must turn off power and set brake).
- Use great care in wet conditions, because the wheelchair brakes are less effective if wheels or platform are wet.
- Never leave platform outside of vehicle. Return platform to stowed position after use.
- Do not load an oversize wheelchair into vehicle if it is too large to pivot freely inside vehicle.

Read and understand these safety precautions. Review them periodically and ask other operators to read them as well. Contact a Ricon dealer or Ricon Product Support if there are questions.

B. DAILY SAFETY CHECK





Inspect lift before each use and verify the following conditions are met before operating:

- All functions operate properly. DO NOT use if unusual noises or movements exist, and

contact a Ricon dealer or qualified service technician for repair.

- Vehicle interlock is operating properly.
- No objects that may interfere with operation are present.
- General appearance and lubrication are satisfactory and all fasteners are tight.

C. PLATFORM MOTIONS

TABLE 2-1: PLATFORM MOTIONS		
MOVEMENT		DESCRIPTION
	DEPLOY	Platform unfolds, or deploys, out of vehicle from stowed position to floor level position. If equipped with a power door operator, the doors automatically open before lift deploys.
	DOWN	Platform lowers from vehicle floor level position towards ground level. The front rollstop automatically lowers (opens) when platform reaches ground level.
	UP	Platform rises from ground level towards vehicle floor level. The front rollstop automatically rises (closes) when platform leaves ground level.
	STOW	Platform folds, or stows, from vehicle floor level to the stowed position. If equipped with a power door operator, the doors automatically close after lift stows.
END OF TABLE		

NOTE: The up and down motions are possible only when platform is deployed.

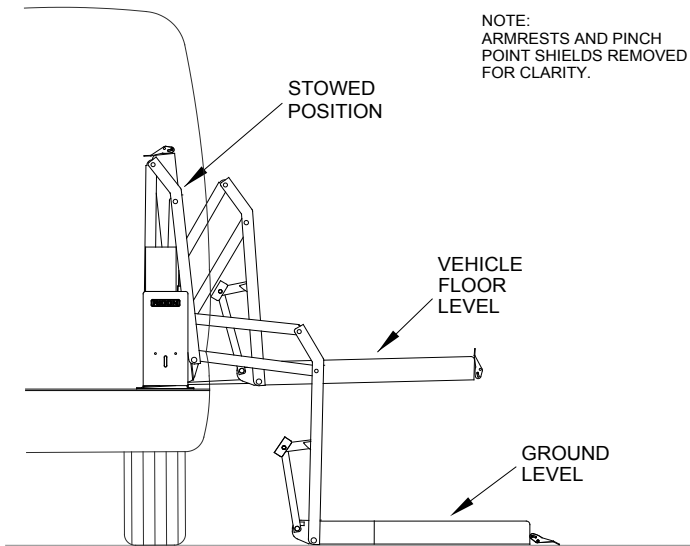

FIGURE 2-4: PLATFORM POSITIONS

D. CONTROLS AND INDICATORS

 WARNING
<p>THE LIFT IS ALLOWED TO OPERATE ONLY WHEN THE VEHICLE MANUFACTURER INTERLOCK CIRCUITRY IS ACTIVATED. IF NECESSARY, REFER TO VEHICLE OPERATOR MANUAL FOR INTERLOCK INSTRUCTIONS. DO NOT ATTEMPT TO OPERATE LIFT WITH INTERLOCK BYPASSED.</p>

■ CONTROL PENDANT

Refer to **Figure 2-5**. The lift is operated with two rocker switches on a hard-wired, hand-held remote control pendant. Control platform movement by pushing and holding one end of a rocker switch. The ends of the switches are referred to in this manual as buttons.

Pushing the DEPLOY button causes the platform to unfold at floor level. Pushing the DOWN button causes the platform to descend towards the ground. Pushing the UP button causes the platform to rise towards floor level. Pushing the STOW button when the platform is at floor level causes it to fold and retract into the vehicle.

Platform motion can be halted at any time by releasing the button. The pendant is usually stored on a wall clip in an interior location that is near the lift.

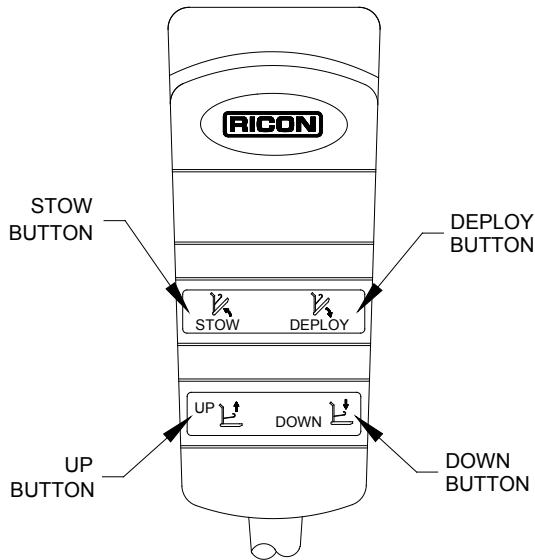

FIGURE 2-5: CONTROL PENDANT

■ CONTROL SWITCH

Refer to **Figure 2-6**. An additional lift control switch is located on the left side platform armrest. The spring-loaded switch lever can be used by the passenger to control UP and DOWN motions of the platform. To move platform downward push and hold switch lever forward, and to move platform upward pull and hold lever back. Release lever at any time to halt motion.

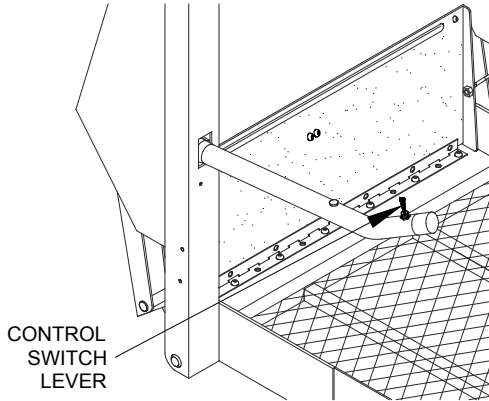

FIGURE 2-6: LIFT CONTROL SWITCH

■ CIRCUIT BREAKERS AND INDICATOR LIGHTS

- Interlock Indicator Light

Refer to **Figure 2-7**. The purpose of a vehicle interlock system is to prevent operation of lift if an unsafe condition is present. When a vehicle interlock system is interfaced with the lift circuitry, the interlock indicator shows whether or not the interlock is operating properly. The light is interfaced with the electrical system so that regardless of which interlock system is used, the light will be on when the interlock provides power to lift and off when interlock has removed power to lift. When there is no interlock system installed, the light stays illuminated at all times.

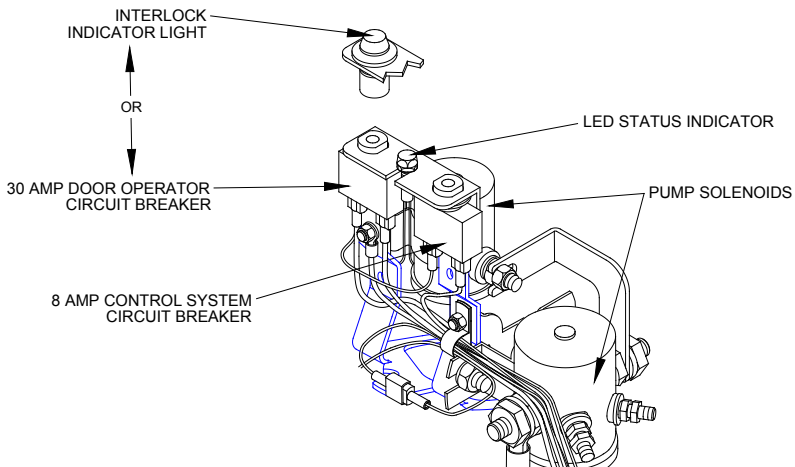

FIGURE 2-7: INDICATOR LIGHT, CIRCUIT BREAKERS, AND LED INDICATOR

Main Circuit Breaker

Refer to **Figure 2-8**. The main circuit breaker is located in the vehicle engine compartment and is used to interrupt electrical power to the lift electrical system when a major short circuit occurs. In such an event, the circuit breaker reset tab will “flip-down”. If pressing reset tab back up (as shown by arrow) and releasing it does not reset power, do not press and hold tab. Contact a Ricon dealer or qualified service technician for repair.

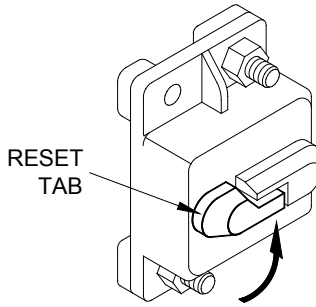

FIGURE 2-8: MAIN CIRCUIT BREAKER

- Optional Door Operator Circuit Breaker

Refer to **Figure 2-7**. The circuit breaker for optional door operator is located on the hydraulic pump assembly. In case of a door operator short circuit, the circuit breaker button will “pop-out”. If pressing and releasing button does not reset power, do not press and hold. Contact a Ricon dealer or qualified service technician for repair. Refer to appropriate Remote Power Door operator manual for a detailed description.

- Control System Circuit Breaker

Refer to **Figure 2-7**. The Control System Circuit Breaker is located on the hydraulic pump assembly. In case of a control system short circuit, circuit breaker button will “pop-out”. If pressing and releasing button does not reset power, do not press and hold. Contact a Ricon dealer or qualified service technician for repair.

- Pump Solenoid LED Status Indicator

Refer to **Figure 2-7**. A second pump solenoid is installed next to the original pump solenoid and a green LED is located between the 8A and 30A circuit breakers. The LED monitors the condition of the two solenoids. The LED is on when the pump is operating, and off when the pump is off. For more information on this LED refer to the service manual 32DSSP06.

- BRIDGEPLATE LOAD SENSOR

Refer to Figure 1-1 and Table 1-1 (in Chapter 1) for the location of the switch that detects the presence of a load on the bridgeplate. When the sensor switch detects that an object is present on the bridgeplate it inhibits lowering of the platform. This protects the passenger from possible injury when the bridgeplate rises. It also protects the bridgeplate from damage, which could later interfere with proper operation of the lift.

■ THRESHOLD SAFETY WARNING SYSTEM

Refer to **Figure 2-9** for the location of threshold warning system components. The lift incorporates two light beams that detect when a passenger (or object, such as a wheelchair) is in the vicinity of the baseplate (threshold area). The beams are enabled when the platform is one inch, or more, below the vehicle floor. If someone passes through either of the beams when the platform is one inch below the floor an audible buzzer is actuated. This system provides a margin of safety for lift users by warning them if the platform is below floor level. The platform must be at floor level when boarding the platform prior to exiting the vehicle.

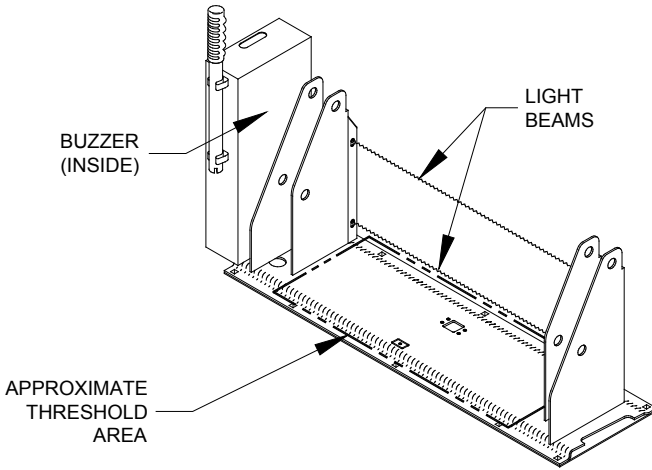

FIGURE 2-9: THRESHOLD WARNING SYSTEM

■ MANUAL BACK-UP PUMP

Refer to **Figure 2-10**. The manual backup pump is located inside the hydraulic pump housing, and is used to operate the lift if electrical power is not functioning. Controls for the pump consist of a pump handle to raise the platform and a pump pressure release valve to lower it. Instructions for operating manual pump are provided in the **MANUAL OPERATION** paragraph, which is part of the **LIFT OPERATION** section in this chapter.

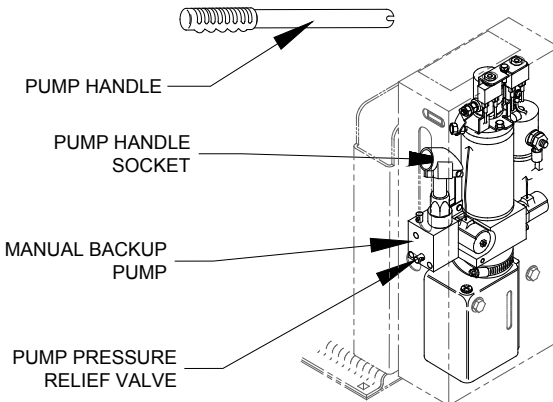

FIGURE 2-10: MANUAL BACKUP PUMP & HANDLE

■ LIFT CYCLE COUNTER

Refer to **Figure 2-11**. The cycle counter is located inside the hydraulic pump housing and visible through a slot on the rear side. The counter advances each time the platform moves through a complete cycle, which consists of the platform moving from the vehicle floor to the ground and back to the floor. The number of cycles displayed is used to schedule maintenance operations.

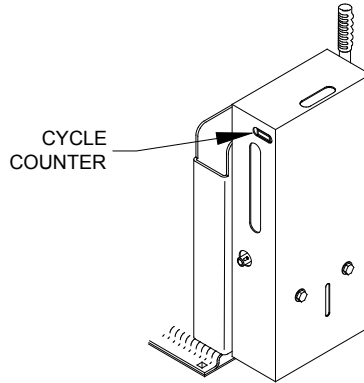

FIGURE 2-11: CYCLE COUNTER

E. NORMAL LIFT OPERATION



WARNING

- IMPROPER USE OF LIFT CAN RESULT IN PERSONAL INJURY. USERS MUST READ AND FOLLOW OPERATING INSTRUCTIONS. ADDITIONAL COPIES OF OPERATOR MANUAL ARE AVAILABLE FROM:

RICON CORP
1135 AVIATION PLACE
SAN FERNANDO, CA 91340
(800) 322-2884

- DO NOT EXCEED RATED LOAD CAPACITY OF 600 POUNDS (273 KGS).
- PRIOR TO USE, INSPECT WHEELCHAIR LIFT FOR PROPER FUNCTION, REQUIRED MAINTENANCE, OR DAMAGE. IF A PROBLEM EXISTS, DO NOT USE LIFT AND CONTACT A RICON DEALER OR QUALIFIED SERVICE TECHNICIAN FOR REPAIR.
- THIS LIFT IS DESIGNED FOR USE BY WHEELCHAIR OCCUPANTS ONLY.

RICON CORPORATION DISCLAIMS LIABILITY FOR DAMAGE OR PERSONAL INJURY RESULTING FROM MODIFICATION TO LIFT, LACK OF MAINTENANCE OR REPAIR, NEGLIGENCE, ABUSE, OR FAILURE TO FOLLOW LIFT OPERATING INSTRUCTIONS.

- Before operating lift, be certain vehicle is safely parked on a level area away from traffic. Provide space for lift operation and passenger boarding.
- The lift operator must take special care to be certain that area is clear before deploying lift. Be certain there are no obstacles beneath platform.
- Open doors completely if lift is not equipped with a power door operator. If so equipped, the vehicle doors will automatically open before platform deploys and close after platform is stowed.
- If equipped with a safety interlock mechanism (e.g. transmission, parking brake, etc) be certain that it is properly engaged before attempting to operate lift. The lift will not operate until this feature has been engaged properly.



WARNING

IF POSSIBLE, SOMEONE SHOULD BE NEAR LIFT PASSENGER TO RENDER IMMEDIATE ASSISTANCE IF NECESSARY.

1. ENTERING VEHICLE:

- a. **DEPLOY PLATFORM** - Push and hold DEPLOY button until platform is completely unfolded from vehicle and stops at floor level.
- b. **LOWER PLATFORM** - Push and hold DOWN button until platform is at ground level and front rollstop is fully lowered.
- c. Carefully place wheelchair in center of platform, **facing outward** (away from vehicle), and lock wheelchair brakes.

**CAUTION**

Be certain wheelchair is clearly within perimeter of platform and does not interfere with operation of rollstop.

- d. **RAISE PLATFORM** - Push and hold UP button until platform rises and stops automatically at floor level.
- e. Release wheelchair brakes and carefully enter vehicle.
- f. Refer to "Stowing Platform" section below to stow platform.

2. EXITING VEHICLE:

- a. **DEPLOY PLATFORM** - Push and hold DEPLOY button until platform is completely unfolded from vehicle and stops at floor level.

**WARNING**

VERIFY THAT PLATFORM IS AT VEHICLE FLOOR LEVEL AND THAT FRONT ROLLSTOP IS UP AND LOCKED IN POSITION.

- b. Carefully place wheelchair in center of platform, **facing outward** (away from vehicle), and lock wheelchair brakes.

**CAUTION**

Do not stand on bridgeplate as platform lowers.

- c. **LOWER PLATFORM** - Push and hold DOWN button until platform is at ground level and front rollstop is fully lowered.
- d. Release wheelchair brakes and carefully exit platform.
- e. Refer to "STOWING PLATFORM" section below to stow platform.

3. STOWING PLATFORM:

- a. If platform is at ground level, push and hold UP button until platform rises and stops automatically at floor level.
- b. Push and hold STOW button until platform folds completely into vehicle.

**CAUTION**

Be certain platform has stowed completely before attempting to close doors. To avoid damage to doors, do not release STOW button until lift pump motor stops automatically.

- c. Close vehicle doors if lift is not equipped with a power door operator. If equipped with a power door operator, the vehicle doors will automatically close after platform is stowed.

F. MANUAL OPERATION

The lift can be operated manually if the lift is not functioning or the primary electrical power source is absent. Ricon recommends that manual operation be used only for exiting passengers from vehicle.

Preparation:

- Be certain vehicle is on a level area and away from traffic. Allow space for platform movement plus space to exit from platform.
- The vehicle operator must summon assistance to move vehicle to a safe area if a break down situation exists where vehicle cannot be moved under its own power.
- Open doors manually if vehicle is not equipped with a power door operator. If equipped with a power door operator, refer to its operator manual for manual operation directions.



NOTE: The threshold warning system is not active during manual operation and cannot be used to indicate platform height.

1. DEPLOY PLATFORM

- Refer to **Figure 2-12**. Override the stow lock feature by lifting bridgeplate by hand. This will separate the Stow lock catch (fastened to underside of bridgeplate) from Stow lock latch (fastened to baseplate). If the stow lock is difficult to separate, use the manual backup pump to raise platform slightly and remove tension from catch; refer to "Stow Platform" paragraph in this section.

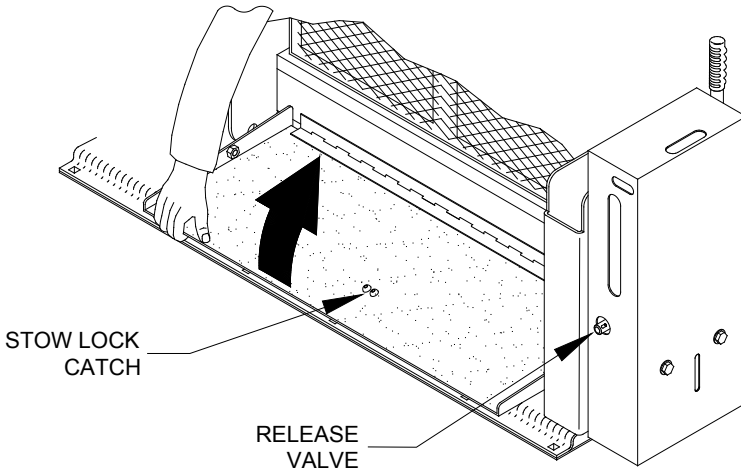
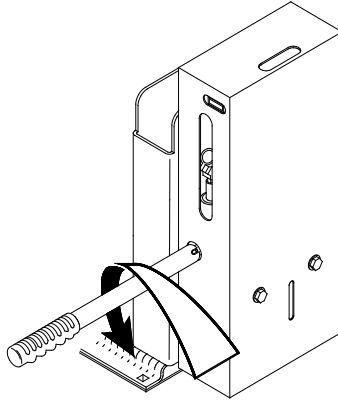

FIGURE 2-12: RAISE BRIDGEPLATE BY HAND

- Refer to **Figure 2-13** on following page. Insert notched end of pump handle into circular hole on hydraulic pump cover and engage pump release valve.

**CAUTION**

Do not open pump release valve more than $\frac{1}{4}$ turn. Opening valve further may cause it to disengage from pump body, which will disable manual pump.

**FIGURE 2-13: OPEN RELEASE VALVE**

- c. Refer to **Figure 2-13**. Open release valve by turning it $\frac{1}{4}$ turn counter-clockwise and platform will begin to lower.
- d. Refer to **Figure 2-14**. When platform reaches vehicle interior floor level turn valve clockwise to close; do not over-tighten valve. Do not lower platform below vehicle floor level. The rear edge of bridgeplate must rest flat on vehicle floor.

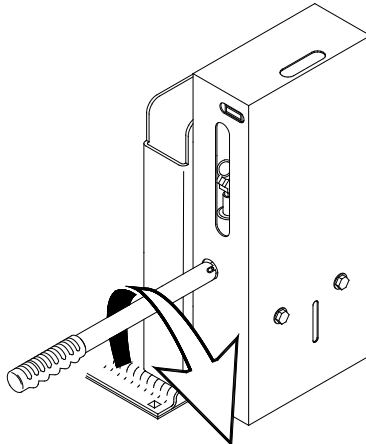
**FIGURE 2-14: CLOSE RELEASE VALVE**

- e. Load Passenger
Carefully place wheelchair in center of platform, facing outward (away from vehicle), and lock wheelchair brakes.

2. LOWER PLATFORM

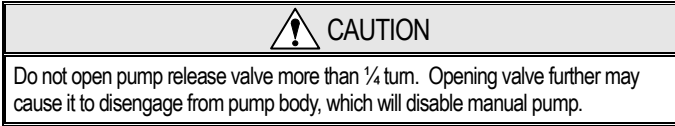

- a. Refer to **Figure 2-13**. Turn valve 1/4 turn counter-clockwise to begin lowering platform.
- b. Hold valve open until platform settles at ground level. Refer to **Figure 2-14**. Turn valve clockwise to close; do not over-tighten valve.
- c. The outer barrier will open automatically as the platform settles to the ground.
- d. Release wheelchair brakes and carefully exit platform.

3. STOW PLATFORM

- a. Refer to **Figure 2-14**. Verify that pump release valve is closed; do not over-tighten valve.
- b. Refer to **Figure 2-15**. Insert pump handle into pump handle socket. Operate pump to begin folding platform.

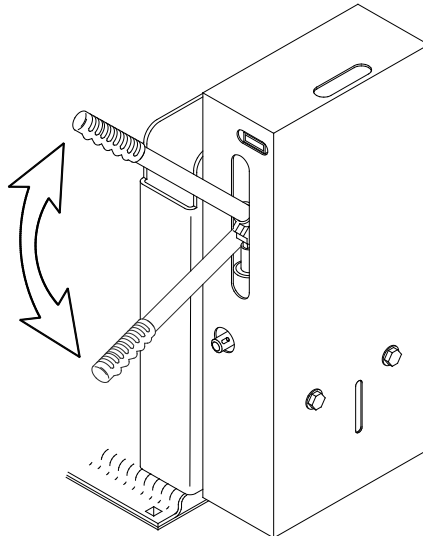

FIGURE 2-15: RAISE PLATFORM

- c. Operate pump until platform is completely folded inside vehicle and Stow lock has engaged.
- d. Stow pump handle. Close vehicle doors.

G. MAINTENANCE AND REPAIR NOTE

Follow the lubrication, cleaning, and maintenance instructions in the following chapter, MAINTENANCE. These instructions are meant to optimize the operating condition of wheel-chair lift.

This page intentionally left blank.

III. S-SERIES® PRIVATE USE LIFT MAINTENANCE

Regular maintenance of the Ricon S-Series® Private Use wheelchair lift will provide optimum performance and reduce the need for repairs. This chapter contains cleaning instructions, a maintenance schedule, and decal information.

A. ADDITIONAL MAINTENANCE INFORMATION

Additional maintenance information is available in the S-Series Private Use service manual, part number 32DSSP06. This manual is available from Ricon in printed hard copy, or at the Ricon website in PDF format. The website is located at www.riconcorp.com. At the website, click on “Technical Documents”, “I agree”, and then “Service Manuals”.

 WARNING
<p>THIS RICON PRODUCT IS HIGHLY SPECIALIZED. MAINTENANCE AND REPAIRS MUST BE PERFORMED BY A RICON DEALER OR QUALIFIED SERVICE TECHNICIAN USING RICON REPLACEMENT PARTS. MODIFYING OR FAILING TO PROPERLY MAINTAIN THIS PRODUCT WILL VOID WARRANTY, AND MAY RESULT IN UNSAFE OPERATING CONDITIONS.</p>



B. CLEANING

Regular cleaning with mild soap (i.e. liquid hand soap or car wash liquid) and drying thoroughly will protect lift painted surfaces. Cleaning is especially important in areas where roads are salted in winter. Make sure that lift pivot points are clean and dry prior to lubrication.

C. MAINTENANCE SCHEDULE

Refer to cycle counter located on rear side of hydraulic power unit. Under normal operating conditions, maintenance inspections are required at the frequencies listed in **Table 3-1**. 10 cycles is considered an average number of cycles for one day.

TABLE 3-1: MAINTENANCE SCHEDULE	
SERVICE POINT	ACTION TO PERFORM
10 CYCLES	
Overall condition	Listen for abnormal noises as lift operates (i.e. grinding or binding noises.)
Control pendant	Verify that control pendant is undamaged and cable connector is tight.
Threshold warning system	Verify that system properly detects objects in threshold area and actuates the audible alarm.
Bridgeplate load sensor	Verify that sensor inhibits downward movement of platform when a weight is present on lowered bridgeplate.
150 CYCLES	
Electrical wiring	Inspect electrical wiring for frayed wires, loose connectors, etc.
Vehicle interlock	Place vehicle in non-interlock mode and verify that lift does not operate.
Decals	Verify that lift decals are properly affixed, clearly visible, and legible. Replace, if necessary.
Armrests	Verify that armrest fasteners are properly tightened.

TABLE 3-1: MAINTENANCE SCHEDULE	
SERVICE POINT	ACTION TO PERFORM
Lift mounting points	<ul style="list-style-type: none"> ▪ Verify that vehicle mounting and support points are undamaged. ▪ Verify that mounting bolts are sufficiently tight and free of corrosion.
Main lifting pivots	Verify that link pins on arms are properly installed, free from damage, and locked in position.
Platform pivot points	Verify that platform moves freely, without binding, and does not wobble.
Bridgeplate	<ul style="list-style-type: none"> ▪ Verify that bridgeplate operates without binding during lift functions. ▪ Verify that bridgeplate deploys fully when platform stops at floor level. ▪ Verify bridgeplate rests flat against baseplate.
Front rollstop	<ul style="list-style-type: none"> ▪ Verify that rollstop is opened completely when platform is at ground level. ▪ Verify that rollstop closes and locks when platform leaves ground.
Hydraulic power unit	 CAUTION
	Check and add fluid when platform is at ground level. Fluid that is added when platform is raised will overflow when platform is lowered.
	<ul style="list-style-type: none"> ▪ Verify that pump hydraulic fluid level is at FULL mark when platform is at ground level. Add Texaco 01554 Aircraft Hydraulic Oil or equivalent U.S. mil spec H5606G fluid. ▪ Verify there are no hydraulic fluid leaks. ▪ Verify that manual backup pump operates properly.
1800 CYCLES	
Cleaning and lubrication	<ol style="list-style-type: none"> 1. Clean lift with mild soap and water and wipe dry. Prevent rust by coating all surfaces with a lightweight oil. Remove excess oil. 2. Spray penetrating oil (Curtisol® Red Grease 88167 or WD-40®) where specified in the service manual 32DSSP04 following directions on container. Remove excess grease from surrounding areas.
 CAUTION	
A Ricon dealer or qualified service technician must perform the annual safety check.	
ANNUAL SAFETY CHECK (or 3600 cycles of operation)	
Hydraulic cylinder, hoses and fittings	<ul style="list-style-type: none"> ▪ Check hydraulic cylinder for evidence of leaks. ▪ Inspect hydraulic hoses for damage. ▪ Verify that all fittings are tight.
END OF TABLE	

D. DECAL PART NUMBERS AND LOCATIONS

Refer to **Figure 3-1**. Inspect decals at interval in **Table 3-1**. Inspect for chipping, peeling, fading, and illegibility. Order replacement decals with part number given in **Figure 3-1**, and apply where shown.

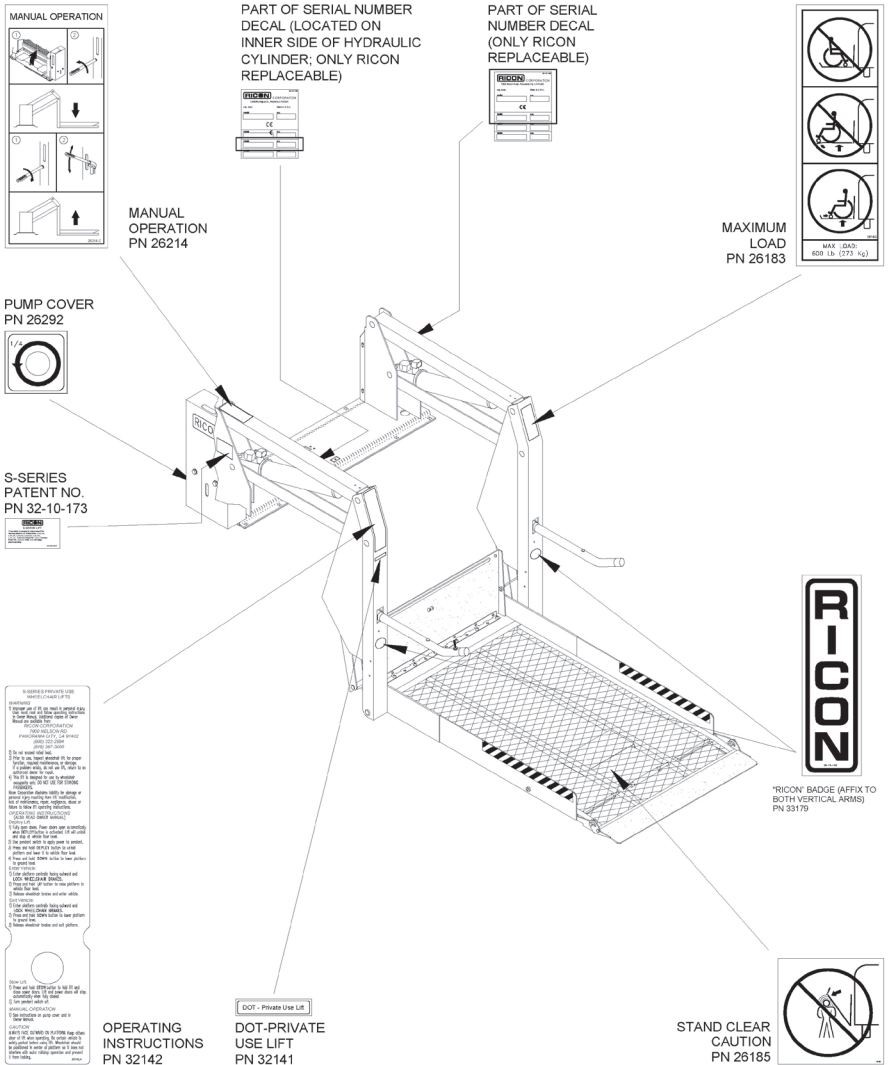

FIGURE 3-1: S-SERIES PRIVATE USE LIFT DECAL LOCATIONS AND PART NUMBERS

This page intentionally left blank.