



MID-SHIP APPLICATION



LUGGAGE BAY INSTALLATION

RICON: EXPERIENCE, RELIABILITY, COMMITMENT

Ricon has been providing innovative accessibility solutions for nearly 40 years, and has worked with most major transit bus, motorcoach and railcar builders in the US, Canada and abroad. We have supplied engineered solutions for transit systems in New York, New Jersey, Chicago, Los Angeles and Miami, and for such operators as Greyhound, METRA and CALTRAIN, among others.

Ricon's commitment to reliability is evident in the solid-state electronic controls that provide the most dependable products in today's market. All Ricon transit and rail product designs are tested to meet or exceed all elements of FMVSS 403/404, 49 CFR part 38 (ADA), CSA D409 and DDA EC2001-85.

By offering one of the most extensive warranties in the industry – with extended warranty coverage also available – Ricon also shows its commitment to its customers. Our technical support includes both in-house and field technicians. On-site service training classes may be arranged.

Ricon also provides supplemental field support in high-demand areas through its association with its factory-trained and -certified service organizations. And we help keep things rolling by ensuring quick and accurate deliveries from our dedicated spare parts warehouse.



AFT OF TAG APPLICATION

TRANSIT & RAIL ACCESSIBILITY SOLUTIONS

HIGH FLOOR BUS & RAIL APPLICATIONS



MIRAGE



MIRAGE MOTORCOACH



MIRAGE TRANSIT

WHEELCHAIR LIFT SOLUTIONS ENGINEERED FOR MOTORCOACH, TRANSIT & RAIL APPLICATIONS

Ricon offers a line of under floor wheelchair lifts that are always available when you need them and nearly invisible when you don't. The Mirage is a cassette type lift that offers reliable operation with minimal impact to the luggage bay. The BAYlift's unique cubic design is compact, allowing it to fit

into installation applications that other lifts will not. Both the Mirage and BAYlift are FMVSS compliant and will help you meet the new OTRB regulations. Let Ricon be your partner in accessibility.



BAYlift MOTORCOACH

MADE IN THE USA



Ricon

A Wabtec company

RICON CORPORATION
A Division of Vapor Bus International
7900 NELSON ROAD • PANORAMA CITY, CA 91402
TOLL-FREE: 1-800-322-2884 • E-Mail: info@RiconCorp.com

www.RiconCorp.com

(09-2007-5M)

Ricon Corp. reserves the right to discontinue models or options at any time or change specifications, materials, equipment or pricing without notice and without incurring obligation.

© 2007 Ricon Corp.



WORLD-CLASS TRANSIT & RAIL ACCESSIBILITY SOLUTIONS

Versatility is key to being a leader in the industry. Ricon products offer many application possibilities. Manufactured in the USA, our lifts are durable enough to serve transit, motorcoach & rail markets. Stepwell applications make the Mirage an ideal choice for transit and railcar installs, while our dedicated entry designs have defined the standard for today's motorcoaches.

- FMVSS and ADA compliant
- Self-contained modular design
- Easy to operate and maintain
- Available extended warranty

www.RiconCorp.com

Ricon innovations begin at our 225,000 square foot corporate headquarters and state of the art manufacturing facility.



MIRAGE

- *Low profile cassette design*
- *Minimal impact on luggage bays*
- *Standee handrails with occupant restraint belt*

PRODUCT SCHEMATICS

The following standard technical drawings and measurements are not meant to be all-inclusive as most installations are scalable and made to order. For more information and a product consultation, please give us a call.

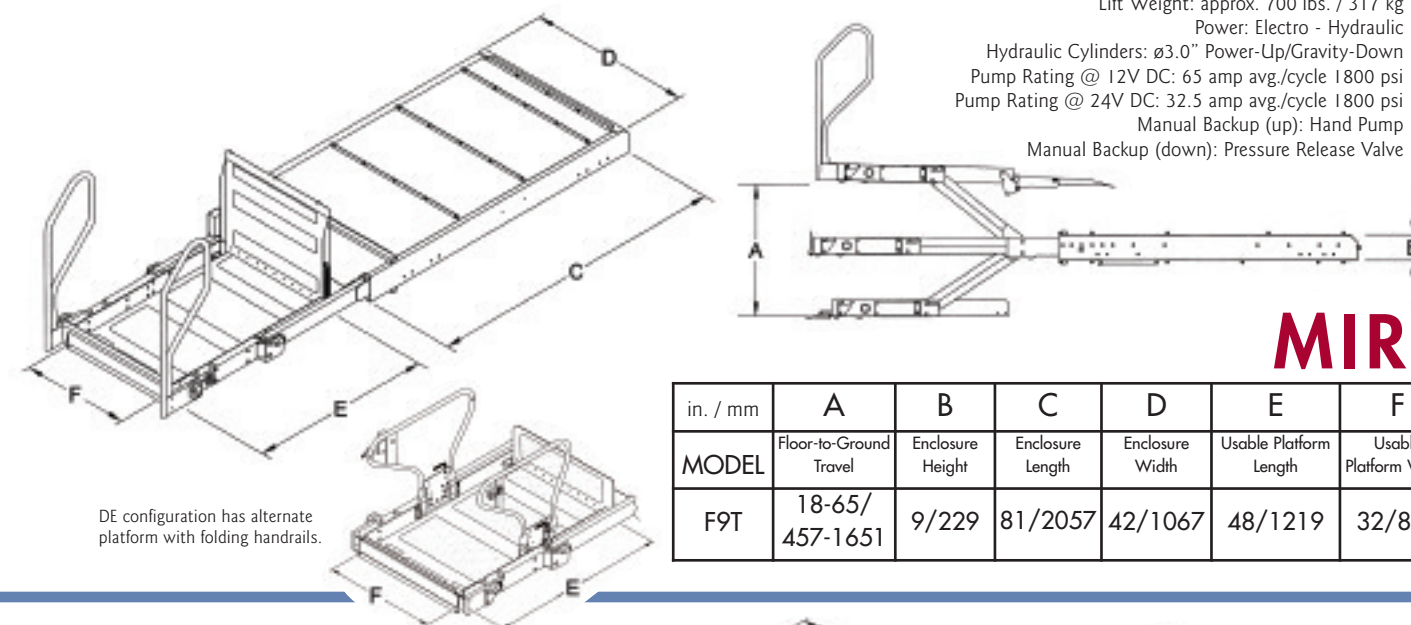

Rated Load Capacity: 660 lbs. / 300 kg
 Lift Weight: approx. 700 lbs. / 317 kg
 Power: Electro - Hydraulic
 Hydraulic Cylinders: ø3.0" Power-Up/Gravity-Down
 Pump Rating @ 12V DC: 65 amp avg./cycle 1800 psi
 Pump Rating @ 24V DC: 32.5 amp avg./cycle 1800 psi
 Manual Backup (up): Hand Pump
 Manual Backup (down): Pressure Release Valve

MIRAGE

in. / mm	A	B	C	D	E	F	G
MODEL	Floor-to-Ground Travel	Enclosure Height	Enclosure Length	Enclosure Width	Usable Platform Length	Usable Platform Width	Clear Entry Width
F9T	18-65/ 457-1651	9/229	81/2057	42/1067	48/1219	32/813	32/813

DE configuration has alternate platform with folding handrails.

BAYlift

- *Versatile compact design*
- *Durable construction*
- *Patented threshold warning system with audible & visual displays*

Rated Load Capacity: 600 lbs. / 272 kg
 Lift Weight: approx. 590 lbs. / 268 kg
 Power: Electro - Hydraulic
 Hydraulic Cylinders: (2) ø1.75" Single-Acting/Gravity-Down
 Pump Rating @ 24V DC: 65 amp avg./cycle 1800 psi
 Manual Backup (up): Hand Pump
 Manual Backup (down): Pressure Release Valve

BAYlift

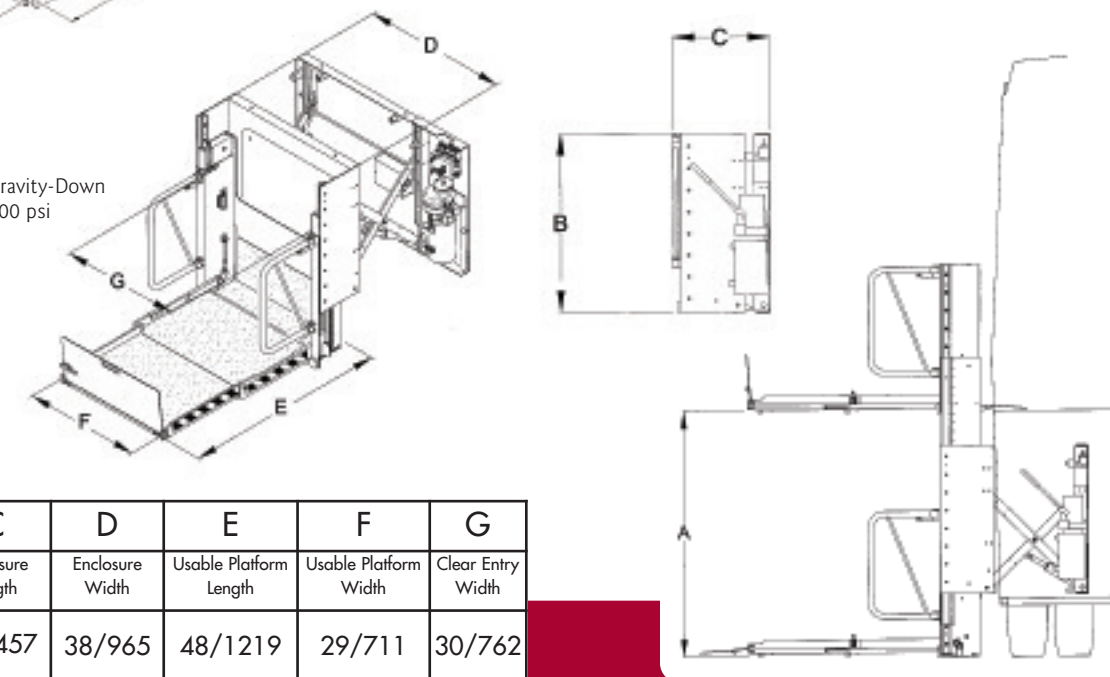

in. / mm	A	B	C	D	E	F	G
MODEL	Max Floor-to-Ground Travel	Enclosure Height	Enclosure Length	Enclosure Width	Usable Platform Length	Usable Platform Width	Clear Entry Width
SSBF	62/1575	37/940	18/457	38/965	48/1219	29/711	30/762

Measurement Name	Description
Floor-to-Ground Travel	Maximum distance the lift can travel from the ground to the vehicle floor
Enclosure Height	Total height when in the stowed position
Enclosure Length	Total length when in the stowed position
Enclosure Width	Total width when in the stowed position
Usable Platform Length	Length of the portion of the platform that can carry a passenger
Usable Platform Width	Width of the portion of the platform that can carry a passenger
Clear Entry Width	The entry width required to receive the platform at floor level

Ricon products are for "DOT PUBLIC USE" vehicles and are compliant with all FMVSS, ADA and many international regulations.